

Real-time monitoring of beta-D-glucuronidase activity in sediment laden streams: A comparison of prototypes



Philipp Stadler^{a, b, *, 1}, Günter Blöschl^{a, c, 1}, Wolfgang Vogl^d, Juri Koschelnik^d,
Markus Epp^d, Maximilian Lackner^d, Markus Oismüller^{a, 1}, Monika Kumpan^{e, 2},
Lukas Nemeth^b, Peter Strauss^{e, 2}, Regina Sommer^{f, g, 3, 4}, Gabriela Ryzinska-Paier^h,
Andreas H. Farnleitner^{f, h, 3}, Matthias Zessner^{a, b, 1}

^a TU Wien, Centre for Water Resource Systems, Karlsplatz 13, A-1040 Vienna, Austria

^b TU Wien, Institute for Water Quality, Resources and Waste Management, Karlsplatz 13, A-1040 Vienna, Austria

^c TU Wien, Institute of Hydraulic Engineering and Water Resources Management, Karlsplatz 13/222, A-1040 Vienna, Austria

^d Vienna Water Monitoring, Dorfstrasse 17, A-2295 Zwerndorf, Austria

^e Federal Agency for Water Management, Institute for Land & Water Management Research, 3252 Petzenkirchen, Austria

^f Interuniversity Cooperation Centre for Water and Health, Gumpendorferstraße 1a, A-1060 Vienna, Austria

^g Medical University of Vienna, Institute for Hygiene and Applied Immunology, Water Hygiene, Kinderspitalgasse 15, A-1090 Vienna, Austria

^h TU Wien, Institute of Chemical Engineering, Research Group Environmental Microbiology and Molecular Ecology, Gumpendorferstraße 1a, A-1060 Vienna, Austria

ARTICLE INFO

Article history:

Received 17 December 2015

Received in revised form

19 May 2016

Accepted 23 May 2016

Available online 27 May 2016

Keywords:

Enzymatic activity

Escherichia coli

Faecal pollution

Glucuronidase

Online monitoring

Water quality

ABSTRACT

Detection of enzymatic activities has been proposed as a rapid surrogate for the culture-based microbiological pollution monitoring of water resources. This paper presents the results of tests on four fully automated prototype instruments for the on-site monitoring of beta-D-glucuronidase (GLUC) activity. The tests were performed on sediment-laden stream water in the Hydrological Open Air Laboratory (HOAL) during the period of March 2014 to March 2015. The dominant source of faecal pollution in the stream was swine manure applied to the fields within the catchment. The experiments indicated that instrument pairs with the same construction design yielded highly consistent results ($R^2 = 0.96$ and $R^2 = 0.94$), whereas the results between different designs were less consistent ($R^2 = 0.71$). Correlations between the GLUC activity measured on-site and culture-based *Escherichia coli* analyses over the entire study period yielded $R^2 = 0.52$ and $R^2 = 0.47$ for the two designs, respectively. The correlations tended to be higher at the event scale. The GLUC activity was less correlated with suspended sediment concentrations than with *E. coli*, which is interpreted in terms of indicator applicability and the time since manure application. The study shows that this rapid assay can yield consistent results over a long period of on-site operation in technically challenging habitats. Although the use of GLUC activity as a proxy for culture-based assays could not be proven for the observed habitat, the study results suggest that this biochemical indicator has high potential for implementation in early warning systems.

© 2016 The Authors. Published by Elsevier Ltd. This is an open access article under the CC BY-NC-ND license (<http://creativecommons.org/licenses/by-nc-nd/4.0/>).

1. Introduction

Agricultural activities may cause faecal pollution in surface water and groundwater (Blann et al., 2009; Bradford et al., 2013; Buck et al., 2004; Farnleitner et al., 2010, 2011). Streams receiving agricultural runoff often contain pathogenic bacteria from manure (Hutchison et al., 2004; Jones, 1999; Mawdsley et al., 1995; Tyrrel and Quinton, 2003). Thus, the real-time detection of faecal pollution in surface waters has high potential for use-orientated protection of water resources.

* Corresponding author. Present address: TU Wien, Centre for Water Resource Systems, Karlsplatz 13/222, 1040 Wien, Austria.

E-mail address: stadler@waterresources.at (P. Stadler).

¹ www.waterresources.at.

² www.baw-ikt.at.

³ www.waterandhealth.at.

⁴ www.meduniwien.ac.at.

Cultivation-based standard analyses of faecal pollution typically require one to several days and are therefore not suitable for rapid water quality assessment (Cabral, 2010). Methods involving enzymatic activity have been tested in various aquatic habitats and have been suggested as surrogates for culture-based microbiological pollution monitoring (Farnleitner et al., 2001, 2002; Fiksdal and Tryland, 2008; Garcia-Armisen et al., 2005). There are various chromogenic and fluorogenic substrates for the specific detection of enzymatic activities, such as beta-D-glucuronidases (GLUC), galactosidases and esterases (Fiksdal et al., 1994; Morikawa et al., 2006; Noble and Weisberg, 2005; Rompré et al., 2002; Wildeboer et al., 2010). Although these common enzymatic activity measurements for faecal indicators require laboratory facilities and elaborate sampling methods (Lebaron et al., 2005; Rompré et al., 2002), research within the last two decades has focused on developing rapid enzymatic assays (Fiksdal et al., 1994; George et al., 2000). However, these assays still require manual sampling and laboratory analytics.

Recent technological developments have brought automated on-site measurements of enzymatic activity within the reach of real time monitoring (Koschelnik et al., 2015; Ryzinska-Paier et al., 2014; Zibuschka et al., 2010). These studies have mainly been conducted for groundwater. The measurements are more challenging for surface waters because of the larger temperature variations and potentially high sediment concentrations. In this study, a field test of instruments for automated on-site enzymatic activity detection for stream water with high suspended sediment loads resulting from runoff events was conducted to understand the strengths and limitations of the instruments and optimize the measurement setup.

2. Materials and methods

2.1. Site description

The methodological basis of the field test conducted in this study is a comparison of automated rapid on-site GLUC measurements with culture-based microbiological measurements as well as with hydrological data in the HOAL - Hydrological Open Air Laboratory (Blöschl et al., 2011, 2015). The HOAL in Petzenkirchen (Lower Austria) is operated and maintained by the Institute for Land and Water Management Research (Federal Agency for Water Management, Austria) and the Vienna Doctoral Programme of Water Resource Systems (Centre for Water Resource Systems, TU Wien, Austria).

The HOAL catchment is 0.66 km² in size and drained by a stream 620 m in length. Twelve point discharges contribute to the stream, including tile drains, springs and surface tributaries (Exner-Kittridge et al., 2013a, b). The mean annual precipitation during the 1990–2014 period was 823 mm/yr. The land use of the catchment is dominated by agriculture, consisting of 87% arable land, 5% grassland, 6% forested area and 2% paved land. The hydrogeology is characterized by porous and fissured aquifers consisting of clay, marl and sand. The soils exhibit medium to limited infiltration capacities. The annual sediment erosion is approximately 10 t/km² (Eder et al., 2010). The main source of faecal contamination of groundwater and surface water is swine manure applied to the fields. In 2014, manure was applied in March, April, August and October, with a typical rate of 20 m³/0.1 km².

The stream has high discharge dynamics (Table 1) with a rapid response to rain events, causing significant peaks in the concentration of suspended sediments in the stream water. Typically, sediments re-suspended from the riverbed control the sediment concentrations early in the event, whereas sediments from the

hillslopes dominate later in the event (Eder et al., 2014). A considerable proportion of sediments stem from tile drainages. Relatively brief, intense events can cause a significant increase in sediment concentrations. Thus, the site is ideal for testing measurement methods under demanding conditions with strong variations in the weather conditions, hydrology, land use management and microbiological impact.

The instrumentation of the HOAL included on-line measurements of water level for discharge determination, electrical conductivity (EC), turbidity and water temperature (Table 1) at the stream monitoring station MW (Fig. 1), which is located at the catchment outlet (see Blöschl et al., 2015 for details). The turbidity measurements were calibrated with grab samples and referenced to the total suspended solid concentrations (TSS mg/l).

Winter and spring 2014 were characterized by fairly low discharges, resulting in an annual average of 2.4 l/s for 2014. Rain events in late spring, summer and autumn caused several high discharge peaks, with a maximum (hourly average) of 73.4 l/s in May 2014 at station MW (Table 1). The minimum discharge in 2014 of 0.5 l/s was recorded in August. The stream water temperature was continuously monitored because of the importance of temperature regarding enzymatic activity in aquatic habitats (Chróst, 1989). Stream water temperature generally tracked the annual trend in air temperature. Water temperature reached a minimum of 0.2 °C in January 2014 and a maximum of 20 °C in July 2014 (Table 1). The average water temperature in 2014 was 10.3 °C. Diurnal fluctuations of water temperature (up to ± 7 °C in April 2014) exhibited maximum values in the afternoon and minimum values in the early morning. The turbidity in the monitored stream is highly event-linked, as rain events promptly cause an increase in the suspended solids in the stream water. Maximum suspended sediment concentrations of over 3 g/l TSS (Table 1) were recorded in July 2014 and January 2015.

2.2. Automated on-site GLUC measurements

At location MW (Fig. 1), two ColiMinder devices (Vienna Water Monitoring - VWM GmbH, Zwerndorf, Austria) for rapid on-site GLUC monitoring have been operating in parallel since March 2014. At the same location, two BACcontrol devices for rapid on-site GLUC monitoring (MicroLan, Waalwijk, Netherlands) have also been operating in parallel since 2012 (only measurements after the installation of an improved sampling set-up in July 2014 were used in this study). Both devices detect beta-D-glucuronidase enzymatic activity and record and transmit the data on a continuous basis. The measurement is based on the optical detection of highly fluorescent 4-Methylumbelliferon (MU), that is produced due to the enzymatic hydrolyses of substrate 4-Methylumbelliferyl-β-D-glucuronid (MUG) at defined conditions (for details see Sigma-Aldrich assay EC 3.2.1.31). Incubation temperature of all tested prototypes was set to 44.0 ± 0.1 °C according to George et al. (2000). More information about incubation time, pH adjustment and calibration can be found in Ryzinska-Paier et al. (2014) and Koschelnik et al. (2015).

The ColiMinder is based on a flow-through photometric measurement chamber (patent: PCT/AT2011/000497), which enables a high-resolution fluorescence analysis. The shapes of the measuring chamber and fluidic system are optimized for automated water sampling, reagent dispensing and effectiveness in the cleaning process. A data correction algorithm (patent: PCT/AT2014/050036) was used to obtain accurate fluorescence readings independent of turbidity. The GLUC activity measurements were performed in batches using 6.5 ml of sample per measurement. The measurement step takes approximately 15 min, and the full measurement cycle, including cleaning and sample

Table 1
Range of key parameters in the HOAL stream during the test period (March 2014–March 2015) (n = number of samples). The figures for GLUC activity (ColiMinder and BACTcontrol) as a biochemical indicator are shown in bold.

			Min	Max	Median	Mean
Discharge	[l/s]	n = 8760	0.5	73.4	2.3	2.6
Suspended solids	[TSS mg/l]	n = 8760	0.0	3210	8.0	18.7
Electrical conductivity	[μ S/cm]	n = 8760	260	856	769	765
Water temperature	[$^{\circ}$ C]	n = 8760	0.2	20.0	10.7	10.3
Air temperature	[$^{\circ}$ C]	n = 7099	-8.7	34.9	12.2	11.6
<i>E. coli</i>	[MPN/100 ml]	n = 54	<1	3450	172	632
GLUC activity (ColiMinder)	[mMFU/100 ml]	n = 3360	0.8	170	10.9	15.8
GLUC activity (BACTcontrol)	[pmol/min/100 ml]	n = 846	1.1	108	9.7	11.5

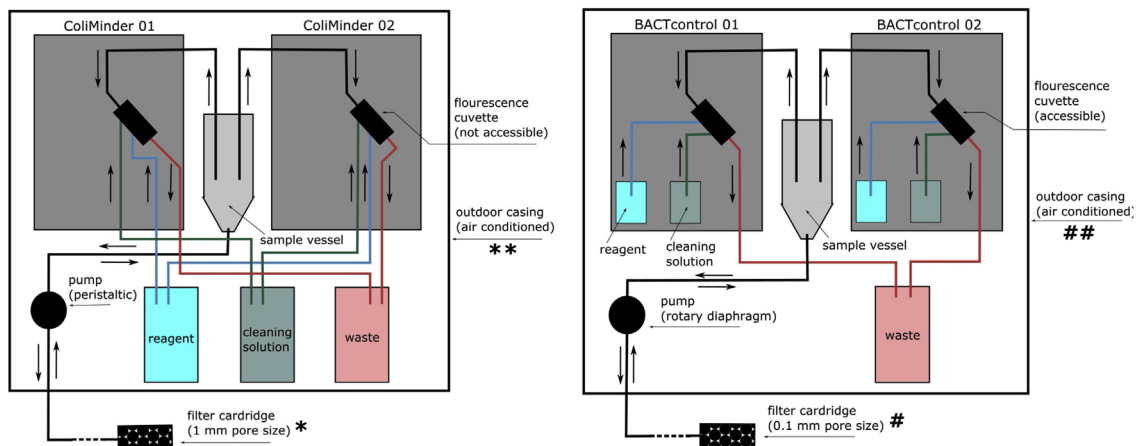

Fig. 1. Top: Photography of the measurement station “MW” showing the monitored stream, the outdoor casings of ColiMinder (left, marked by asterisks) and BACTcontrol (right, marked by hash tags), and the discharge flume. The sample intake of ColiMinder is located on the right side of the stream (marked by an asterisk), whereas that of BACTcontrol is located on the left side of the stream (marked by a hash tag). Bottom: Schematic of the basic construction of ColiMinder (left) and BACTcontrol (right).

conditioning, lasts 30–40 min. ColiMinder is calibrated to Modified Fishman Units (MFU/100 ml) based on the enzyme unit definition for beta-glucuronidase activity (Bergmeyer, 2012; Fishman and Bergmeyer, 1974). The measurement interval has been chosen as 60 min.

The BACTcontrol devices (formerly Coliguard) have a different

design. The construction design and sampling and measurement procedure of the BACTcontrol devices have been described in detail by Zibuschka et al. (2010) and Ryzinska-Paier et al. (2014), respectively. The devices provide units of pmol/min/100 ml. The measurement interval was 3 h.

The ColiMinder and BACTcontrol devices are connected to 230 V

of AC power and accommodated in temperature-controlled, weatherproof casings, where reagents and cleaning solutions were also stored (Fig. 1). The sample intakes of both constructions are located 20 cm below the water level on opposite stream sides. During the measurement process, the sample mixed with specific assay reagents (proprietary information) generates an increasing fluorescence signal reflecting the level of enzymatic activity, which is monitored over time. Internal control parameters, such as the fluorescence signal, the linearity of the fluorescence slope, the temperature of the measurement chamber, the device's environmental temperature, the measurement duration and blank value measurements, are available for each data point and were used for quality control of the measurement results. All devices are connected to an on-site wireless data transfer GPRS-modem via an Ethernet interface, enabling on-line access to the measurement data.

The fundamental differences between the two constructions (Fig. 1) include the following: the fluorescence measurement chamber (ColiMinder: Measurement chamber not accessible; BACTcontrol: Measurement chamber accessible), the pore size of the filter mounted at the sample intake (ColiMinder: 1 mm; BACTcontrol: 0.1 mm), the pump used to deliver water samples to a sample container shared by the devices of each construction (ColiMinder: Peristaltic pump; BACTcontrol: Rotary diaphragm pump), the arrangement of the reagent and cleaning solutions (ColiMinder: Shared reagent and cleaning solution containers for both devices; BACTcontrol: Separate reagent and cleaning solution containers per devices); and, most importantly, different reagent and cleaning solutions and different photometric measurements.

2.3. Inter-comparison of on-site GLUC measurements

To test the consistency of the on-site GLUC measurements, data from two prototypes of the same design were compared. In addition, data from the instruments with different designs were compared. For the latter comparison, the measurement data were aligned to the following full hour for consistency, as ColiMinder devices did not yet allow for arbitrary time stamps.

Although the units of measurements are different, all designs provide the same target-parameter, namely, the determination of beta-D-glucuronidase activity in water. The unit of BACTcontrol (pmol/min/100 ml) measures enzymatic activity (pmol of fluorophore per minute and per 100 ml); the unit of ColiMinder (mMFU/100 ml) is similar, but it references the enzymatic activity to known conditions (i.e., those published by Fishman). For any direct comparison of the measurements, it would be ideal to determine the hydrolysis rate of each device using a series of standard solutions with known enzymatic activity, pH and reaction temperature; however, this information is proprietary to the companies and could thus not be used in this paper. Therefore, direct comparisons of the measurement results with different units are presented.

2.4. Quality screening of on-site GLUC measurements

In addition to internal control parameters, comparisons of measurements from devices with the same design were used to assess their validity. The normalized absolute percentage difference of the readings, ΔS , was calculated as follows:

$$\Delta S = \text{abs} \left(\frac{S_{01} - S_{02}}{S_{01}} \right) * 100 \quad (1)$$

where S_{01} and S_{02} are the readings of the two devices.

For quality screening, the ΔS (%) values were compared to the GLUC measurements for each construction. To determine the potential effects of environmental parameters on the consistency of measurements, ΔS (%) values were compared with turbidity, water temperature, air temperature, suspended sediment concentrations and discharge.

2.5. Reference sampling survey of culture-based *Escherichia coli*

To test the capability of on-site GLUC measurements as a quantitative proxy for fecal derived *E. coli*, GLUC measurements were compared with the following microbiological standard assays: ISO 9308-2 (Most-Probable-Number (MPN) method, Colilert 18, IDEXX Laboratories Inc., USA; incubation at 36 ± 2 °C for 20 ± 2 h) (ISO, 2012) and ISO 16649 (membrane filtration method, chromogenic TBX agar, Oxoid, Thermo Fisher Scientific Inc., United Kingdom; incubation at 44 ± 0.5 °C for 44 ± 4 h) (ISO, 2001). Fifty-four grab samples were taken manually during the test period for reference and analysed with the method ISO 9308-2. This total number comprises samples from a continuous reference sampling campaign conducted on an approximately monthly basis ($n = 10$), samples from three runoff events ($n = 31$) and intermittent grab samples during base flow conditions ($n = 13$). Microbiological analysis (ISO 9308-2 and ISO 16649-1) data from monthly grab samples are available for a period of three years (2012–2015), characterizing the range of faecal indicator bacteria (FIB) during base flow conditions in the monitored stream. MPN values were used in this study as a proxy for standard culture-based assays due to the strong correlation between *E. coli* concentrations determined with the ISO 9308-2 (MPN/100 ml) and ISO 16649-1 (CFU/100 ml) methods ($R^2 = 0.94$, $n = 25$, p -value < 0.001, monthly grab samples 2012–2015) and the higher number of reference samples analysed during the test period with ISO 9308-2.

2.6. Event monitoring of culture-based *E. coli*

To investigate the utility of the instruments for capturing abrupt changes of GLUC activity during rainfall events, several runoff events were sampled in more detail. Automated sampling devices (ISCO sampler 6712) triggered by water level-thresholds were used for event sampling. ISCO samplers were linked to a pressure transducer (GE Sensing, PTX 1830 or Ott PSI) that measures the water level. Two auto-samplers capable of sampling up to 30 h with a total of 48 bottles were installed at station MW. The first device sampled at 15-min intervals when the programmed water-level threshold was exceeded. After the first 24 bottles were filled, autosampling automatically switched to a second device, which sampled every hour. The auto samplers were equipped with sterile bottles for microbiological event monitoring. One bottle in each auto sampler was employed as a blank for quality control purposes to detect any inadvertent contamination of coliform bacteria that may result from the procedure. The “blank bottle” followed an identical procedure as the sample bottles and remained in the auto sampler from installation to removal without being filled. Instead, it was rinsed after the sampling campaign with 100 ml of sterile water that was subsequently analysed with method ISO 9308-2 for *E. coli* and coliform bacteria. The MPN analyses of “blank bottles” indicated an absence of contaminant *E. coli* and coliform bacteria, confirming the validity of the procedure. Event-samples were retrieved within 5 h, refrigerated, and analysed within 8 h after sampling.

Precipitation and air temperature data from a weather station located in the centre of the catchment were also used in the analyses.

3. Results

3.1. Consistency of measurements

GLUC measurements of the devices with the same construction design were highly consistent throughout the measurement period (Fig. 2A, Fig. 2B). Linear correlation coefficients (R^2) of 0.94 and 0.96 were found between the two ColiMinder devices (Fig. 2A) and the two BACTcontrol devices, respectively (Fig. 2B) (all p -values < 0.001). The regression slopes are 0.88 and 0.89, respectively, and the offsets are small. The correlations between devices with different designs (Fig. 2C, D) exhibit reasonable consistency ($R^2 = 0.71$), with slopes of 0.85 and 0.98, respectively. ColiMinder and BACTcontrol obtained samples from opposite sides of the stream (Fig. 1), and the sampling times may differ by up to 1 h, which likely contributes to the lower correlations. Nevertheless, the measurement results of the two designs exhibit a highly symmetrical range of signals and an average one-to-one ratio between mMFU/100 ml (ColiMinder) and pmol/min/100 ml (BACTcontrol) (Fig. 2). The same construction designs exhibited an offset relative to each other that is slightly less than half the mean base-GLUC activity monitored during a large portion of the test period (i.e., ColiMinder 01 yielded consistently higher results than ColiMinder 02 by +2 mMFU/100 ml, and BACTcontrol 01 yielded consistently higher results than BACTcontrol 02 by +1.5 pmol/min/100 ml). The offset of ColiMinder exceeded their lower limit of detection (0.8 mMFU/100 ml), whereas the offset of BACTcontrol was within the lower limit of detection (1.5 pmol/min/100 ml).

3.2. Influence of environmental parameters on GLUC measurement consistency

As a first step, the normalized absolute differences of the readings, ΔS , of similar devices were compared with the GLUC readings (Fig. 3A). The BACTcontrol devices generally yield higher differences in readings than ColiMinder; however, the average ΔS does not exceed 40% for either of the designs. A comparison of the ΔS values with sediment concentrations (TSS) (Fig. 3C) does not indicate a systematic increase in ΔS with higher TSS values. The concentration of suspended solids in stream water (up to 3200 mg/l TSS) clearly did not directly affect the consistency of the measurement results. This result also applies to the comparison of ΔS values with discharge (Fig. 3D). There was no evidence that water temperature water temperature (0.2–20 °C) had a negative effect on the consistency of the measurements (not shown here). In contrast, the comparison of ΔS values with air temperature (Fig. 3B) indicated significantly higher measurement deviations in the case of ColiMinder for air temperatures exceeding 25 °C (Fig. 3B, grey shade). Due to these deviations, the substrate tempering within the instrument was improved by installing a thermoelectric cooling module (Peltier cooler), which eliminated this negative effect.

3.3. Comparison with culture-based analyses

On-site GLUC measurements and grab sample analyses with culture-based methods of *E. coli* measurements yielded a high consistency (Table 2). For the entire dataset (Table 2), ColiMinder

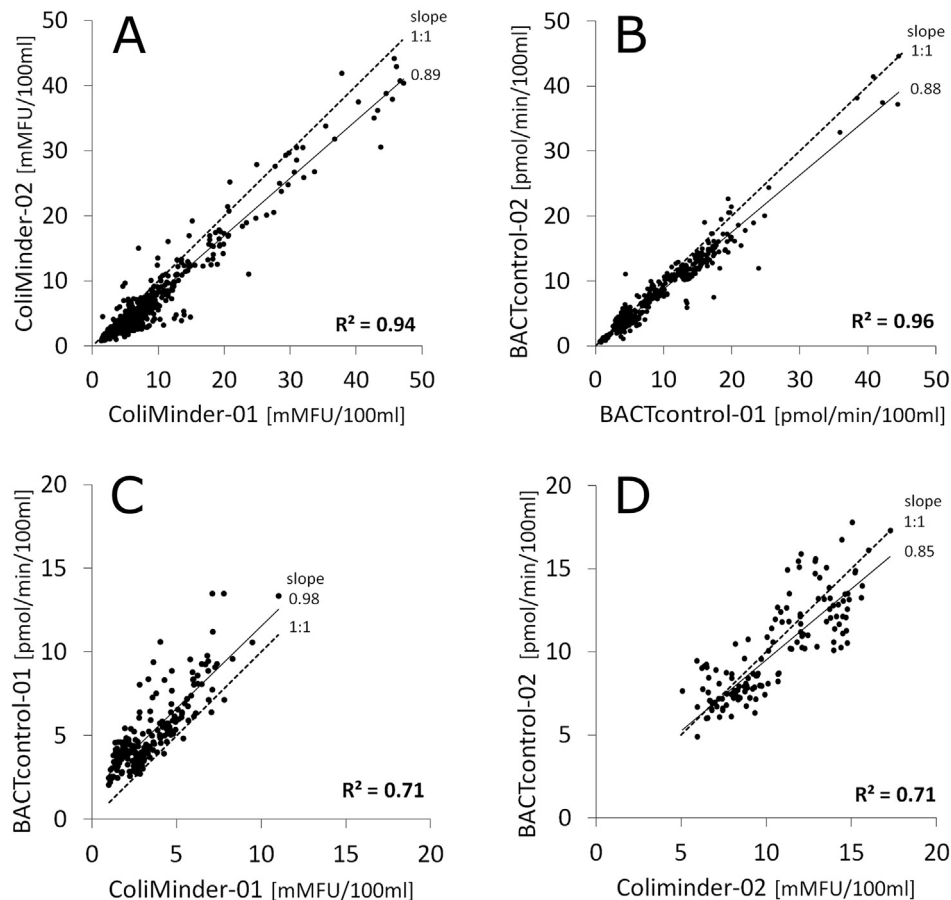

Fig. 2. Comparison of GLUC measurements from ColiMinder and BACTcontrol prototypes operated in parallel. A and B: Data from devices with the same design yield highly consistent results ($R^2 > 0.90$, p -value < 0.001). C and D: Data from devices with different designs yield comparable results ($R^2 = 0.71$, p -values < 0.001). Range of signals varies between panels C and D due to different test periods.

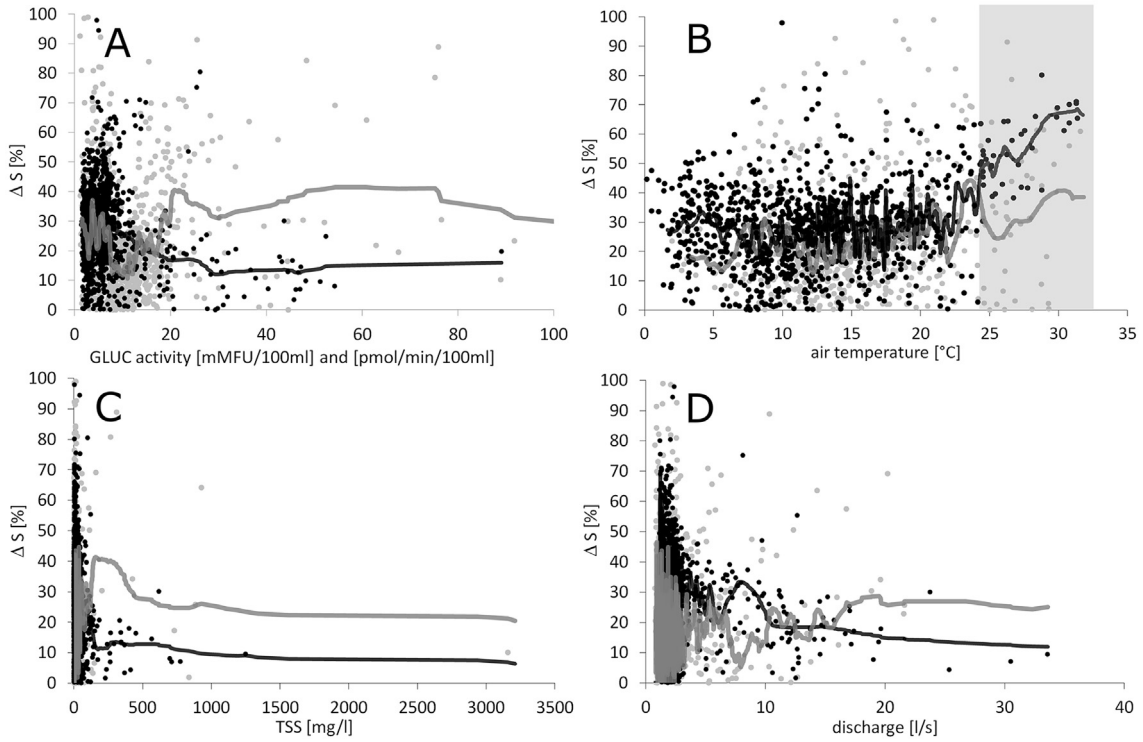

Fig. 3. Influence of environmental parameters on the consistency ΔS of GLUC measurements (ColiMinder: black dots, moving average: black line. BACTcontrol: grey dots, moving average: grey line). GLUC activity (A), air temperature (B), total suspended solids (TSS) (C) and discharge (D). Notes: A: ColiMinder generally yielded lower readings than BACTcontrol. B: Air temperatures above 25 °C caused increased signal deviation for ColiMinder (grey shaded area). C and D: High TSS concentrations and discharges do not deteriorate the consistency of the GLUC readings.

Table 2

Correlation (linear regression) R^2 between GLUC activity (ColiMinder and BACTcontrol), *E. coli* (MPN) and hydrological parameters. The star code indicates the significance level (***: p -value ≤ 0.001 , **: p -value ≤ 0.05 , for $R^2 \leq 0.1$), n = number of measurements, NMRSE = normalized root mean squared error). Both constructions for GLUC measurements exhibit reasonable correlations to *E. coli*. *E. coli* concentrations are more strongly related to the hydrological parameters, particularly those runoff events indicated.

	GLUC ColiMinder [mMFU/100 ml]	GLUC BACTcontrol [pmol/min/100 ml]	<i>E. coli</i> [MPN/100 ml]	Discharge [l/s]	Electrical conductivity (EC) [μ S/cm]	Sediment concentration (TSS) [mg/l]	Water temperature [°C]
GLUC ColiMinder [mMFU/100 ml]							
GLUC BACTcontrol [pmol/min/100 ml]	0.71*** $n = 378$ NMRSE = 0.35						
<i>E. coli</i> [MPN/100 ml]	0.52*** $n = 54$ NMRSE = 0.74	0.47*** $n = 51$ NMRSE = 0.94					
Discharge [l/s]	0.22*** $n = 3792$ NMRSE = 0.85	0.18*** $n = 836$ NMRSE = 0.89	0.63*** $n = 54$ NMRSE = 0.62				
Electrical conductivity (EC) [μ S/cm]	0.08 $n = 3792$ NMRSE = 0.06	0.12*** $n = 844$ NMRSE = 0.06	0.68*** $n = 54$ NMRSE = 0.06	0.05 $n = 6917$ NMRSE = 0.07			
Sediment concentration (TSS) [mg/l]	0.24*** $n = 3558$ NMRSE = 2.50	0.22*** $n = 836$ NMRSE = 1.53	0.51*** $n = 53$ NMRSE = 1.11	0.47*** $n = 6571$ NMRSE = 2.85	0.21*** $n = 6571$ NMRSE = 3.47		
Water temperature [°C]	0.11*** $n = 3792$ NMRSE = 0.26	0.10*** $n = 845$ NMRSE = 0.26	0.14*** $n = 54$ NMRSE = 0.18	0.01 $n = 6917$ NMRSE = 0.28	0.17*** $n = 6917$ NMRSE = 0.26	0.00 $n = 6571$ NMRSE = 0.28	
Air temperature [°C]	0.01 $n = 2353$ NMRSE = 0.42	0.00 $n = 523$ NMRSE = 0.36	0.18** $n = 30$ NMRSE = 0.30	0.04 $n = 5272$ NMRSE = 0.39	0.06 $n = 5272$ NMRSE = 0.38	0.00 $n = 4936$ NMRSE = 0.37	0.74*** $n = 5272$ NMRSE = 0.10

vs. MPN yielded $R^2 = 0.52$, and BACTcontrol vs. MPN yielded $R^2 = 0.47$ ($n = 50$, p -values < 0.001). The correlations tended to increase when examining individual runoff events. For example, the event in February 2014 (shown in Fig. 4D) yielded $R^2 = 0.8$ (p -value < 0.001 , $n = 13$).

In the test period (March 2014 to March 2015), *E. coli* concentrations in monthly base flow had a maximum in July 2014 (*E. coli*: 780 CFU/100 ml and 770 MPN/100 ml) and a minimum in March 2014 (*E. coli*: 2.6 CFU/100 ml and < 1 MPN/100 ml). The GLUC data from all four instruments exhibited a similar pattern. The monthly mean of the GLUC signals increases tenfold from March 2014 to August 2014 (Fig. 4B), which corresponds well with the microbiological standard assays.

3.4. Event dynamics

All devices were able to detect rapid fluctuations in enzymatic activity in stream water caused by changes in the hydrological conditions in the catchment (Fig. 4B, D). All monitored runoff events caused an increase in the stream water GLUC activity. GLUC

measurements from the two construction designs exhibited the same trends and dynamics regarding timing and amplitude (Fig. 4D). Due to the different measuring intervals of the tested prototypes (ColiMinder: 1 h, BACTcontrol: 3 h), the ColiMinder measurements reflect rapid changes in GLUC activity in more detail (Fig. 4D). Although the sediment concentration in the stream (Fig. 4A) is strongly correlated with the intensity of rain events or changing run-off conditions (with a higher rain intensity typically resulting in a higher TSS concentration), events with peak values of GLUC activity are not necessarily associated with high-intensity precipitation or high TSS concentrations. This behaviour is illustrated in Fig. 4A and B, where the left grey bar shows a period of consistency between the TSS and GLUC peaks (Fig. 4AB). The right grey bar shows a period of inconsistency. Table 2 also shows that *E. coli* concentrations in the monitored stream are more strongly correlated with hydrological parameters, such as discharge, TSS and EC, than with GLUC activity. In particular, the EC of stream water is strongly related to the *E. coli* concentration ($R^2 = 0.68$) but not to GLUC activity ($R^2 = 0.08$ and $R^2 = 0.12$). Furthermore, comparisons with culture-based FIB

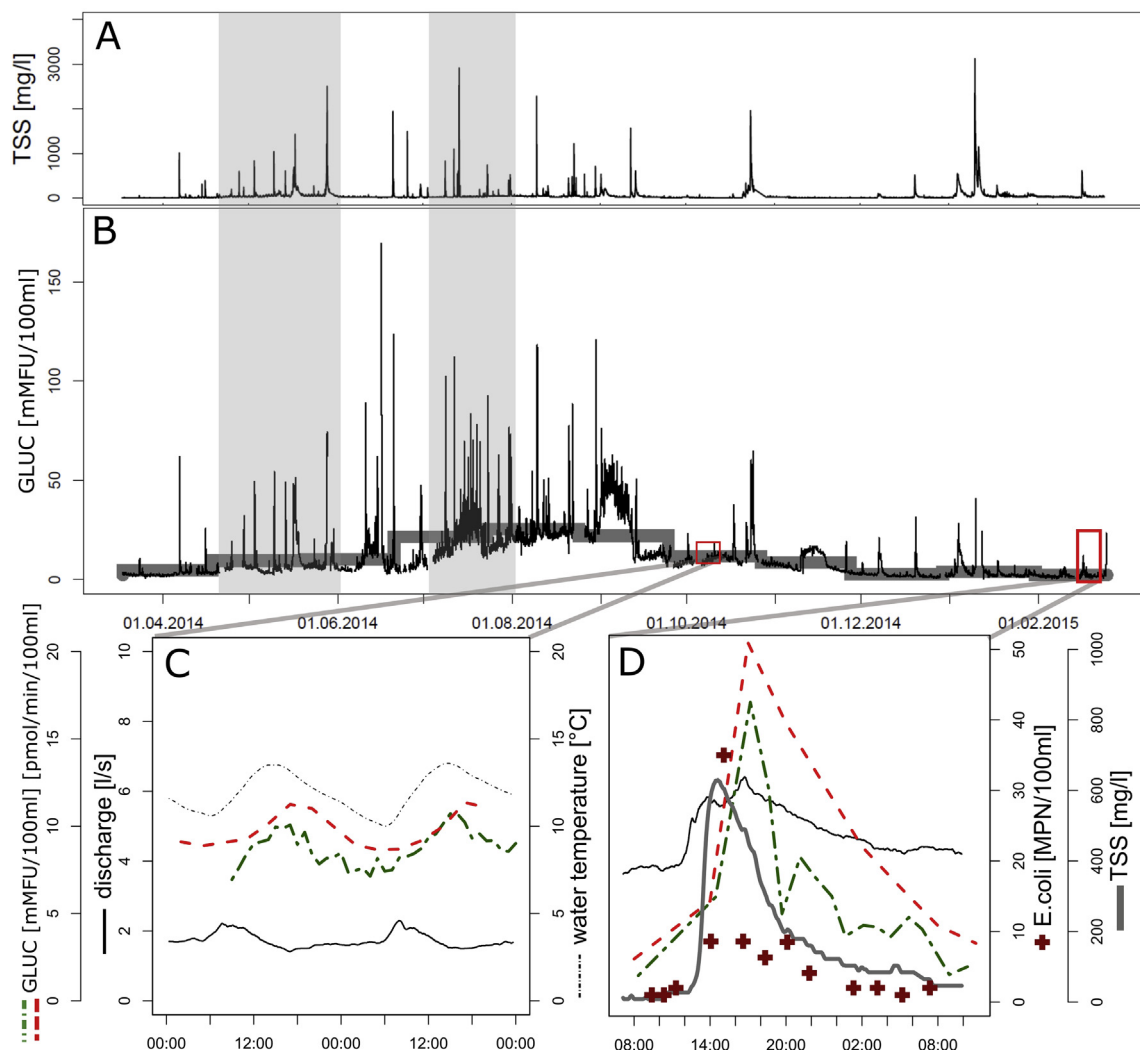

Fig. 4. A: TSS in stream water during the test period (March 2014–March 2015). Peaks of TSS indicate runoff events. B: GLUC activity in stream water during the test period (black) and its monthly mean (grey). The left grey bars in A and B highlight a period of consistency between sediment concentrations and GLUC, and the right bar indicates a period of inconsistency. C: Diurnal dynamics of GLUC activity (green: ColiMinder, red: BACTcontrol), water temperature (dashed line) and discharge (black). D: Event dynamics of GLUC activity (green: ColiMinder, red: BACTcontrol), TSS (grey), discharge (black) and *E. coli* (crosses). Both the diurnal and event dynamics of GLUC are consistent between devices. At the event scale (D), ColiMinder (green) has a higher time resolution, but both devices exhibit a similar dynamic as *E. coli*. (For interpretation of the references to colour in this figure legend, the reader is referred to the web version of this article.)

analyses showed that the GLUC and *E. coli* responses during events are quite similar regarding the timing of the rising limb, although there were differences in terms of the amplitude and recession (Fig. 4D).

3.5. Diurnal fluctuations

The diurnal fluctuations of enzymatic activity (Fig. 4C) in stream water were recorded with the ColiMinder devices installed in March 2014. The daily variation ranged up to 4 mMFU/100 ml. After improving the sampling procedure of the BACTcontrol devices in July 2014, diurnal fluctuation were also captured with these devices within the range of 4 pmol/min/100 ml. During dry periods, all four devices recorded a maximum GLUC activity in the late afternoon, with decreasing activity during night hours, leading to minimum values in the early morning. This pattern has a different phase as the daily discharge fluctuations driven by riverine transpiration and is more closely related to diurnal water temperature (Fig. 4C).

4. Discussion

4.1. General operation of the devices

All tested devices proved to be reliable under the diverse set of field conditions to which they were subjected. The tests showed that consistent and continuous on-site measurement data can be gathered for up to 6 months without technical failure. Of particular concern was the role of high-suspended sediment loads. The devices provided valid measurement data even with TSS concentrations of up to 3 g/l. However, biweekly intervals for the manual cleaning of the instruments were necessary. This interval is considerably shorter than the monthly maintenance reported for applications involving groundwater (Ryzinska-Paier et al., 2014). Damping of the signal because of fine filters was not detected. The rinsing water (de-ionized water) consumption of 85 ml (ColiMinder) and 100 ml (BACTcontrol) per measurement and the chosen temporal resolution of measurements necessitated a weekly refill. Clogging of hoses and valves due to debris deposition occasionally led to erroneous measurements and made it necessary to alternately disconnect the devices for servicing after 3 (ColiMinder) to 6 (BACTcontrol) months of continuous operation. The longer running time until dismounting of the BACTcontrol devices suggests that a 0.1 mm filter should be preferred over a 1 mm filter. Improvements regarding sample pre-filtration, cleaning fluid compounds and temperature control within the devices' outer casing were conducted following the results of this study. Efforts are still underway regarding the most appropriate cleaning and rinsing solutions and the overall optimization for the specific operating environment, particularly with respect to the prevention of biofilm formation and accumulation of particulates within the device. Such upcoming amendments might significantly enhance runtimes between required maintenance. Nevertheless, more research on the effects of pre-filtration upon GLUC activity measurements is needed.

All prototypes of both constructions were able to conduct comparable measurements, reflecting the dynamics of GLUC activity in stream water on various time scales (seasonal, event, diurnal). Due to the lower signal deviation between the ColiMinder devices compared to BACTcontrol and to the shorter measurement intervals, ColiMinder devices might be preferable if one is interested in a high temporal resolution. The accessibility of the measurement chamber for manual cleaning by the operator is a significant benefit of the BACTcontrol construction.

4.2. Range of values

The observed GLUC activity varied during the test period from 0.8 mMFU/100 ml to 170 mMFU/100 ml (ColiMinder) and from 1.1 pmol/min/100 ml to 108 pmol/min/100 ml (BACTcontrol), ranging from the lower limit of detection to a value signifying faecal contamination. These results are consistent with an agricultural catchment subjected to periodic manure application on the crop fields. The GLUC magnitudes are also consistent with previous published studies, ranging between GLUC levels of nearly unpolluted groundwater (Ryzinska-Paier et al., 2014) and stream water influenced by municipal sewage (Farnleitner et al., 2002; Garcia-Armisen et al., 2005; George et al., 2000; Ouattara et al., 2011). The event monitoring showed that the GLUC peaks tend to be aligned with the first flush of event stream runoff. The discharge increase in the early phase of the event may occasionally produce a “wash-out” effect (data not shown). This phenomenon has also been reported in studies on the event-scale transport of faecal-derived coliform bacteria, where analyses were based on culture-based assays (Krometis et al., 2007). Regarding the diurnal fluctuations of the GLUC activity method and construction-based temperature, compensation problems can be eliminated from a technical perspective, as the diurnal fluctuations of enzymatic activity were recorded with BACTcontrol devices for the first time after the sampling procedure was improved but the measurement principle did not change. The reported temperature dependence of bacterial activity likely causes these dynamics in the stream.

4.3. Indicator applicability

For the implementation of automated GLUC measurements as a proxy parameter for culture-based *E. coli* analyses an association between these two parameters of $R^2 > 0.9$ is required (Stadler et al., 2010). The results of this study show, that such requirements were not met and therefore the proxy capability of automated GLUC determination for culture-based *E. coli* could not be proven. Methods of enzymatic activity measurements are ideally capable of detecting the enzymatic activity from all metabolically active target bacteria, including the so-called viable but non-cultivable (VBNC) subpopulation, whereas culture-based methods are not (Cabral, 2010). The association between *E. coli* and GLUC described in this study lies within the range of correlations reported in previous studies. Tight associations between faecal indicator bacteria and GLUC were reported in at least three studies (Farnleitner et al., 2001, 2002; Fiksdal et al., 1994; George et al., 2001) that focused on catchments with influences from municipal sewage (human origin). However, the correlation between *E. coli* and GLUC for catchments under the influence of ruminant faecal sources tends to be poor (Ryzinska-Paier et al., 2014). Although data from the aforementioned studies have not been compared statistically in this paper, the contrasting behaviour suggests that the differences in the association between *E. coli* and GLUC is strongly dependent on the habitat, runoff patterns in the catchment and faecal contamination source types and ages. A dominant source of faecal contamination of stream water in the HOAL is the application of swine manure. The coliform bacteria loads and GLUC activity in the stream likely vary seasonally with changing land management practices and runoff, resulting in an alternating influence of faecal contamination, with varying proportions of the VBNC subpopulation associated with different compartments in the catchment (e.g., soil water, the hyporheic zone or overland flow). One would assume that the highest correlations between *E. coli* and GLUC can be found in catchments under the influence of non-ruminant faecal pollution originating predominantly from one of these compartments. Such conditions have likely occurred in the HOAL through contaminated

runoff during hydrological events, reflected by an R^2 of 0.80 (p -value < 0.001) between *E. coli* and GLUC for single events, such as that in February 2015. During this event, no precipitation occurred and air temperatures rose slightly above zero, which melted frozen soil water in the catchment and produced a significant discharge into the stream (Blöschl et al., 2015).

A comparison of GLUC measurements with hydrologic parameters indicated that although GLUC activity in stream water is fairly poorly correlated with hydrological parameters, it is most closely aligned with TSS. *E. coli* concentrations determined by cultivation-based methods have a stronger correlation with hydrological parameters, particularly the electrical conductivity of stream water, which predominantly indicates the influence of event water in the stream. Although the number of observations from grab samples and that of on-site measurements differ, this suggests that the dynamics of *E. coli* in the HOAL catchment are mainly event-driven, whereas the variations of the GLUC signal in stream water are only linked to runoff events and particle transport to some extent. Catchment conditions, such as the hydrologic state or land management practices as well as the aforementioned source and age of faecal contamination, also play a significant role.

Cross-sensitivity and interference of GLUC activity with non-faecal compounds, such as algae or organic matter, have also been reported (Biswal et al., 2003; Fiksdal and Tryland, 2008; Molina-Muñoz et al., 2007) and may play an additional role in the correlation of enzymatic methods with microbiological standard assays. Furthermore, Togo et al. (2010) reported both amplifying and inhibitory effects on GLUC activity due to the presence of different ions in water samples. Chang et al. (1989) described the abundance of faecal-derived *E. coli* not active with respect to beta-D-glucuronidase. Further research is required to assert the applicability of on-site enzymatic methods, such as a specific indicator for faecal-associated bacteria in different habitats, the role of non-faecal-associated components and their actual influence on the GLUC signal measured on-site.

4.4. Outlook

Current investigations focus on the influence of hydrologic conditions (baseflow or event runoff conditions) on the relation between *E. coli* and GLUC activity. Further research is also required to quantify the GLUC activity of different compartments (soil water, the hyporheic zone and overland flow) contributing to the stream flow (Exner-Kittridge et al., 2013b). Research in the HOAL catchment investigates the influence of land management procedures (e.g., manure application and plowing) on the dynamics of enzymatic activity in stream water and uses the GLUC time series in combination with hydrological methods to identify the pathways and transport processes of potential faecal pollution. Detailed monitoring and field experiments focusing on the diurnal fluctuations of GLUC activity in stream water are currently underway.

5. Conclusions

The results of this study suggest that the potential of real-time monitoring of beta-D-glucuronidase (GLUC) activity is enormous. The implementation of on-site GLUC measurements as a quantifying proxy parameter for culture-based *E. coli* analyses could not be proven in the observed habitat; nevertheless, this biochemical indicator, which may be available on-site and with high temporal resolution, is of great value for understanding catchment behaviour and contaminant transport processes in different habitats. The assessment of the instruments paves the way for a wider application of on-site and online measurements of physicochemical parameters. Automated on-site methods based on specific enzymatic

activity monitoring will likely become a cornerstone of early warning systems that use oriented protection of water resources and process control.

Notes

The authors declare no competing financial or personal interest.

Acknowledgements

The authors thank Ronald W. Harvey (National Research Program, USGS, Boulder) for his constructive comments and advice. We thank Alexander Haider (xamgaom) for his technical support regarding BACControl as well as Günther Schmid and Silvia Jungwirth (Institute for Land and Water Management Research, Federal Agency for Water Management) for their assistance in Petzenkirchen. This study was financially supported by the Austrian Science Fund (W1219-N28) (Vienna Doctoral Programme on Water Resource Systems, W 1219-N22), the Vienna University of Technology (innovative project) and the Austrian Research Promotion Agency.

Appendix A. Supplementary data

Supplementary data related to this article can be found at <http://dx.doi.org/10.1016/j.watres.2016.05.072>.

References

- Bergmeyer, H.U., 2012. *Methods of Enzymatic Analysis*. Elsevier.
- Biswal, N., Gupta, S., Ghosh, N., Pradhan, A., 2003. Recovery of turbidity free fluorescence from measured fluorescence: an experimental approach. *Opt. Express* 11 (24), 3320–3331. <http://dx.doi.org/10.1364/OE.11.003320>.
- Blann, K.L., Anderson, J.L., Sands, G.R., Vondracek, B., 2009. Effects of agricultural drainage on aquatic ecosystems: a review. *Crit. Rev. Environ. Sci. Technol.* 39 (11), 909–1001. <http://dx.doi.org/10.1080/10643380801977966>.
- Blöschl, G., Blaschke, A.P., Broer, M., Bucher, C., Carr, G., Chen, X., Eder, A., Exner-Kittridge, M., Farnleitner, A., Flores-Orozco, A., Haas, P., Hogan, P., Kazemi Amiri, A., Oismüller, M., Parajka, J., Silasari, R., Stadler, P., Strauß, P., Vreugdenhil, M., Wagner, W., Zessner, M., 2015. The hydrological open air laboratory (HOAL) in Petzenkirchen: a hypotheses driven observatory. *Hydrol. Earth Syst. Sci. Discuss.* 12 (7), 6683–6753. <http://dx.doi.org/10.5194/hessd-12-6683-2015>.
- Blöschl, G., Carr, G., Bucher, C., Farnleitner, A.H., Rechberger, H., Wagner, W., Zessner, M., 2011. Promoting interdisciplinary education – the Vienna Doctoral Programme on water resource systems. *Hydrol. Earth Syst. Sci. Discuss.* 8 (6), 9843–9887. <http://dx.doi.org/10.5194/hessd-8-9843-2011>.
- Bradford, S.A., Morales, V.L., Zhang, W., Harvey, R.W., Packman, A.I., Mohanram, A., Welty, C., 2013. Transport and fate of microbial pathogens in agricultural settings. *Crit. Rev. Environ. Sci. Technol.* 43 (8), 775–893. <http://dx.doi.org/10.1080/10643389.2012.710449>.
- Buck, O., Niyogi, D.K., Townsend, C.R., 2004. Scale-dependence of land use effects on water quality of streams in agricultural catchments. *Environ. Pollut.* 130 (2), 287–299. <http://dx.doi.org/10.1016/j.envpol.2003.10.018>.
- Cabral, J.P., 2010. *Water microbiology. Bacterial pathogens and water*. *Int. J. Environ. Res. Public Health* 7 (10), 3657–3703.
- Chang, G.W., Brill, J., Lum, R., 1989. Proportion of beta-D-glucuronidase-negative *Escherichia coli* in human fecal samples. *Appl. Environ. Microbiol.* 55 (2), 335–339.
- Chróst, R.J., 1989. Characterization and significance of β -glucosidase activity in lake water. *Limnol. Oceanogr.* 34 (4), 660–672. <http://dx.doi.org/10.4319/lo.1989.34.4.0660>.
- Eder, A., Exner-Kittridge, M., Strauss, P., Blöschl, G., 2014. Re-suspension of bed sediment in a small stream—results from two flushing experiments. *Hydrol. Earth Syst. Sci.* 18, 1043–1052. <http://dx.doi.org/10.5194/hess-18-1043-2014>.
- Eder, A., Strauss, P., Krueger, T., Quinton, J.N., 2010. Comparative calculation of suspended sediment loads with respect to hysteresis effects (in the Petzenkirchen catchment, Austria). *J. Hydrol.* 389 (1–2), 168–176.
- Exner-Kittridge, M., Niederreiter, R., Eder, A., Zessner, M., 2013a. A simple and flexible field-tested device for housing water monitoring sensors at point discharges. *Water Sci. Technol.* 67 (5), 1026–1033. <http://dx.doi.org/10.2166/wst.2013.655>.
- Exner-Kittridge, M., Salinas, J.L., Zessner, M., 2013b. An evaluation of analytical streambank flux methods and connections to end-member mixing models: a comparison of a new method and traditional methods. *Hydrol. Earth Syst. Sci. Discuss.* 10 (8), 10419–10459. <http://dx.doi.org/10.5194/hessd-10-10419-2013>.

- Farnleitner, A.H., Hocke, L., Beiwil, C., Kavka, G.C., Zechmeister, T., Kirschner, A.K., Mach, R.L., 2001. Rapid enzymatic detection of *Escherichia coli* contamination in polluted river water. *Lett. Appl. Microbiol.* 33 (3), 246–250. <http://dx.doi.org/10.1046/j.1472-765x.2001.00990.x>.
- Farnleitner, A.H., Hocke, L., Beiwil, C., Kavka, G.G., Mach, R.L., 2002. Hydrolysis of 4-methylumbelliferyl- β -D-glucuronide in differing sample fractions of river waters and its implication for the detection of fecal pollution. *Water Res.* 36 (4), 975–981. [http://dx.doi.org/10.1016/S0043-1354\(01\)00288-3](http://dx.doi.org/10.1016/S0043-1354(01)00288-3).
- Farnleitner, A.H., Ryzinska-Paier, G., Reischer, G.H., Burtscher, M.M., Knetsch, S., Rudnicki, S., Dirnböck, T., Kuschnig, G., Mach, R.L., Sommer, R., 2010. *Escherichia coli* and enterococci are sensitive and reliable indicators for human, livestock, and wild life faecal pollution in alpine mountainous water resources. *J. Appl. Microbiol.* 109, 1599–1608.
- Farnleitner, A.H., Reischer, G.H., Stadler, H., Kollanur, D., Sommer, R., Zerobin, W., Blöschl, G., Barrella, K.M., Truesdale, J.A., Casarez, E.A., 2011. In: Hagedorn, C., Blanch, A.R., Harwood, V.J. (Eds.), *Microbial Source Tracking: Methods, Applications, and Case Studies*. Springer, New York, pp. 399–433.
- Fiksdal, L., Pommepuy, M., Caprais, M.P., Midttun, I., 1994. Monitoring of fecal pollution in coastal waters by use of rapid enzymatic techniques. *Appl. Environ. Microbiol.* 60 (5), 1581–1584.
- Fiksdal, L., Tryland, I., 2008. Application of rapid enzyme assay techniques for monitoring of microbial water quality. *Curr. Opin. Biotechnol.* 19 (3), 289–294. <http://dx.doi.org/10.1016/j.copbio.2008.03.004>.
- Fishman, W.H., Bergmeyer, H.U., 1974. β -glucuronidase. *Methods Enzym Anal.* 2, 929.
- García-Armisen, T., Lebaron, P., Servais, P., 2005. Beta-D-glucuronidase activity assay to assess viable *Escherichia coli* abundance in freshwaters. *Lett. Appl. Microbiol.* 40 (4), 278–282. <http://dx.doi.org/10.1111/j.1472-765X.2005.01670.x>.
- George, I., Crop, P., Servais, P., 2001. Use of beta-D-galactosidase and beta-D-glucuronidase activities for quantitative detection of total and fecal coliforms in wastewater. *Can. J. Microbiol.* 47 (7), 670–675.
- George, I., Petit, M., Servais, P., 2000. Use of enzymatic methods for rapid enumeration of coliforms in freshwaters. *J. Appl. Microbiol.* 88 (3), 404–413. <http://dx.doi.org/10.1046/j.1365-2672.2000.00977.x>.
- Hutchison, M.L., Walters, L.D., Moore, A., Crookes, K.M., Avery, S.M., 2004. Effect of length of time before incorporation on survival of pathogenic bacteria present in livestock wastes applied to agricultural soil. *Appl. Environ. Microbiol.* 70 (9), 5111–5118. <http://dx.doi.org/10.1128/AEM.70.9.5111-5118.2004>.
- ISO, 2001. *Microbiology of Food and Animal Feeding Stuffs — Horizontal Method for the Enumeration of Beta-glucuronidase-positive *Escherichia coli*. Part 1: Colony-count Technique at 44 °C Using Membranes and 5-Bromo-4-chloro-3-indolyl-D-glucuronide (ISO 16649-1:2001)*. International Organisation of Standardisation, Geneva, Switzerland.
- ISO, 2012. *Water Quality - Enumeration of *Escherichia coli* and Coliform Bacteria - Part 2: Most Probable Number Method (ISO 9308-2:2012)*. International Organisation of Standardisation, Geneva, Switzerland.
- Jones, D.L., 1999. Potential health risks associated with the persistence of *Escherichia coli* O157 in agricultural environments. *Soil Use Manag.* 15 (2), 76–83. <http://dx.doi.org/10.1111/j.1475-2743.1999.tb00069.x>.
- Koschelnik, J., Vogl, W., Epp, M., Lackner, M., 2015. Rapid analysis of β -D-glucuronidase activity in water using fully automated technology. *Water Resour. Manag.* VIII 196, 471–481. <http://dx.doi.org/10.2495/WRM150401>.
- Krometis, L.A., Characklis, G.W., Simmons III, O.D., Dilts, M.J., Likirdopulos, C.A., Sobsey, M.D., 2007. Intra-storm variability in microbial partitioning and microbial loading rates. *Water Res.* 41 (2), 506–516. <http://dx.doi.org/10.1016/j.watres.2006.09.029>.
- Lebaron, P., Henry, A., Lepeuple, A.-S., Pena, G., Servais, P., 2005. An operational method for the real-time monitoring of *E. coli* numbers in bathing waters. *Mar. Pollut. Bull.* 50 (6), 652–659. <http://dx.doi.org/10.1016/j.marpolbul.2005.01.016>.
- Mawdsley, J.L., Bardgett, R.D., Merry, R.J., Pain, B.F., Theodorou, M.K., 1995. Pathogens in livestock waste, their potential for movement through soil and environmental pollution. *Appl. Soil Ecol.* 2 (1), 1–15. [http://dx.doi.org/10.1016/0929-1393\(94\)00039-A](http://dx.doi.org/10.1016/0929-1393(94)00039-A).
- Molina-Muñoz, M., Poyatos, J.M., Vilchez, R., Hontoria, E., Rodelas, B., González-López, J., 2007. Effect of the concentration of suspended solids on the enzymatic activities and biodiversity of a submerged membrane bioreactor for aerobic treatment of domestic wastewater. *Appl. Microbiol. Biotechnol.* 73 (6), 1441–1451.
- Morikawa, A., Hirashiki, I., Furukawa, S., 2006. Development of a coliforms monitoring system using an enzymatic fluorescence method. *Water Sci. Technol.* 53, 523–532.
- Noble, R.T., Weisberg, S.B., 2005. A review of technologies for rapid detection of bacteria in recreational waters. *J. Water Health* 3 (4), 381–392.
- Ouattara, N.K., Passerat, J., Servais, P., 2011. Faecal contamination of water and sediment in the rivers of the Scheldt drainage network. *Environ. Monit. Assess.* 183 (1–4), 243–257. <http://dx.doi.org/10.1007/s10661-011-1918-9>.
- Rompré, A., Servais, P., Baudart, J., de-Roubin, M.R., Laurent, P., 2002. Detection and enumeration of coliforms in drinking water: current methods and emerging approaches. *J. Microbiol. Methods* 49 (1), 31–54.
- Ryzinska-Paier, G., Lendenfeld, T., Correa, K., Stadler, P., Blaschke, A.P., Mach, R.L., Stadler, H., Kirschner, A.K., Farnleitner, A.H., 2014. A sensitive and robust method for automated on-line monitoring of enzymatic activities in water and water resources. *Water Sci. Technol.* 69, 1349–1358. <http://dx.doi.org/10.2166/wst.2014.032>.
- Sigma-Aldrich: Enzymatic Assay of β -Glucuronidase (EC 3.2.1.31) from *E. coli* [WWW Document], n.d. Sigma-Aldrich. URL <http://www.sigmaaldrich.com/technical-documents/protocols/biology/enzymatic-assay-of-b-glucuronidase-from-ecoli.html> (accessed 12.05.16).
- Stadler, H., Klock, E., Skritek, P., Mach, R.L., Zerobin, W., Farnleitner, A.H., 2010. The spectral absorption coefficient at 254nm as a real-time early warning proxy for detecting faecal pollution events at alpine karst water resources. *Water Sci. Technol. J. Int. Assoc. Water Pollut. Res.* 62, 1898.
- Togo, C.A., Wutor, V.C., Pletschke, B.I., 2010. Properties of in situ *Escherichia coli*-D-glucuronidase (GUS): evaluation of chemical interference on the direct enzyme assay for faecal pollution detection in water. *Afr. J. Biotechnol.* 5 (22).
- Tyrrel, S.F., Quinton, J.N., 2003. Overland flow transport of pathogens from agricultural land receiving faecal wastes. *J. Appl. Microbiol.* 94, 875–935.
- Wildeboer, D., Amirat, L., Price, R.G., Abuknesha, R.A., 2010. Rapid detection of *Escherichia coli* in water using a hand-held fluorescence detector. *Water Res.* 44 (8), 2621–2628. <http://dx.doi.org/10.1016/j.watres.2010.01.020>.
- Zibuschka, F., Lendenfeld, T., Lindner, G., 2010. Near real time monitoring von *E. coli* in Wasser. *Österreichische Wasser Abfallwirtsch.* 62 (11–12), 215–219. <http://dx.doi.org/10.1007/s00506-010-0240-z>.