

PRACTICAL HANDBOOK OF MATERIAL FLOW ANALYSIS

Paul H. Brunner and Helmut Rechberger

Annex: Solutions

- Solution 1.1:** a) MFA is based on the principle of mass conservation. Mass cannot vanish (exception are nuclear reactions, which are not discussed here). b) This supports establishment of materials balances: 1. it serves as a means of control in cases where all flows are known (input = output \pm storage). 2. It can be used to determine one unknown flow per process (cf. Figure 1).

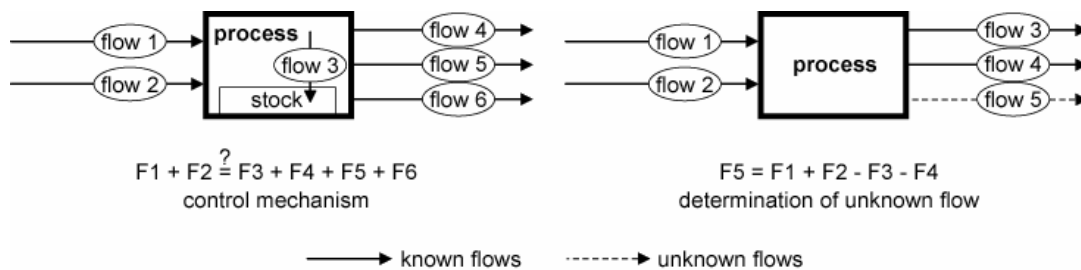

Figure 1 Application of the mass balance principle in MFA. Left side: control whether the process is balanced. Right side: determination of an unknown flow; no control possible

- **Solution 1.2:** cf. Table 1

Table 1 Examples for goods and substances as defined in MFA

Goods	substances
polyvinyl chloride (stabilized, additives)	cadmium (Cd)
wood (cellulose, hemi cellulose, lignin, ash, ...)	nitrogen (N ₂)
drinking water (H ₂ O, trace elements)	melamine (C ₃ H ₆ N ₆)
personal computer (plastics, metals,)	iron (Fe)
steel (Fe, C, additives)	copper (Cu)
brass (Cu-Zn-alloy)	glucose (C ₆ H ₁₂ O ₆)
waste paper (cellulose, H ₂ O, kaolin, printing ink...)	polyvinyl chloride (pure, (-CH ₂ -CHCl-))
copper ore (CuFeS ₂ , minerals, Zn...)	

- **Solution 1.3:** solid materials: without any detailed knowledge it can be assumed that less than 10 kg/(c·d) are used or consumed directly (food, fuels see below, consumer goods); aqueous materials: water consumption is for sure higher (toilet flush, shower, etc.) and >100 kg/(c·d); gaseous materials: air is consumed for breathing, heating/cooling, and transport. Air consumption is probably most easiest to estimate: average travel distance of 30 km/(c·d), fuel consumption is 8 L/(100 km), → daily fuel consumption is 2.4 L/(c·d) or 1.8 kg/(c·d), theoretical air consumption for combustion of gasoline is 15 kg of air per kg of gasoline, air excess rate of the engine is ca. 1.2, → air consumption is $1.8 \cdot 15 \cdot 1.2 = 32$ kg/(c·d); specific energy for space heating is ca. 100 kWh/(m²·yr), specific living area is 40 m²/c, → energy consumption for space heating is around 4 MWh/(c·yr), → this corresponds to ca. 0.33 t fuel oil/(c·yr), → air consumption is ca. 5 t/(c·yr) or 14 kg/(c·d); air consumption for breathing is ca. 30 kg/(c·d).
Result of the assessment: turnover of solid materials <10 kg/(c·d); gaseous materials ≈ 80 kg/(c·d); aqueous materials >100 kg/(c·d). Note that this result is influenced by life style and climate.

- **Solution 1.4:** net growth of stock: $2.7 - 1.0 = 1.7$ kg/(c·yr). Doubling time: $40/1.7 = 24$ yrs.

- **Solution 1.5:** Weighing the food is the cheapest and most accurate means to determine the input. If scale A (range 1g to 2 kg) has an accuracy of 1 % in the range of the food weight of ~ 1 kg, the error is ± 10 g. The error for determination of the weight of the test person (~ 70 kg) by scale B (range 1kg to 200 kg) is also 1 %, equaling ± 700 g. This is the same order of magnitude as the food weight. Hence, if the food weight is determined by two measurements of the test person, the result will be highly inaccurate. To apply both methods is not efficient and most costly; additional information cannot be gained by combining the approaches.

Note that in Figure 1.2a, the test persons chair is suspended on a scale. The principle of mass conservation was not known to Santorio (1561-1636) because Lavoisier (1743-1794) has not been born yet. Hence, for Santorio, it was not a priori clear that the weight of the food eaten corresponds to the difference in weight of the test person!

Solution 1.6: a) “Factor 4” requires a reduction of the mass flows through private households by 64 t/c.yr (86 t/c.yr \rightarrow 22 t/c.yr), and factor 10 a reduction by 77 t/c.yr. The largest potential for decrease holds “to clean”: If technology (water saving appliances, washing machines, toilets and low-flow fixtures) and life style (shower replaces bath, appropriate flushing of toilets, dry-cleaning instead of wet laundering) are optimized towards water conservation, water consumption can be reduced by 50 to 75 % (30 to 45 t/c.yr or 80 to 120 L/c.day). Larger reductions will have a severe impact on life style and technology and subsequently on household economy. “To reside” and “to transport” offer a relatively smaller potential for mass flow reduction: If homes are better insulated, and if fuel consumption of cars is improved, a reduction of fossil fuel consumption by 50 % (minus \sim 7 t/c.yr, cf. Table 1.1 assuming that off gas is the result of fuel combustion for room heating and transportation) can be achieved without a major change in lifestyle. Alternative construction technologies (e.g. concrete versus wood) can change the mass flow, too, but their impacts will be small. Changes in “to nourish” are of no significance because human needs cannot be reduced, and food wastes are comparatively less important. In summary, a reduction in household throughput of 40 to 50 t/c.yr seems possible if resource conservation technologies are applied and if consumers are willing to pay the additional costs. To reach the objective of minus 64 or 77 t/c.yr requires extreme efforts, new technologies, and major changes in lifestyle. b) Advantage: “Factor X” addresses the problem of large material turnovers in a popular way; it stimulates discussion about possibilities and limitations of resource conservation; it represents a measurable criteria. Disadvantage: “Factor X” is solely quantitative, does not include qualitative criteria, e.g. pollution potential of heavy metals or different economic values of resources such as water, concrete or gold; it is a high goal, difficult to reach in practice on a broad base; lack of rationale: is factor 2, 4, 10 or 20 more appropriate?

Solution 1.7:

year	exploitation [kt/year]	to air [kt/year]	to landfill [kt/year]	to water [kt/year]	stock change [kt/yr]	stock [kt]
1980	17	8	2	1	6	200
2003	18 to 20	1.6	2 to 20	0.2	- 3.8 to 16.2	500

a) Pollution abatement measures reduce the anthropogenic deposition of cadmium from 6 kt/yr to 1.2, and reduce the waste water flows from 1 to 0.2 kt/yr. Thus, in contrast to the 1980ies, the cadmium inputs into the soil (without land-filling: 1.2 anthropogenic plus 0.7 kt/yr geogenic) have become smaller than the outputs (4.2 kt/yr); cadmium concentrations in the soil do not increase anymore but are likely to decrease. Of course, this global balance does not take regional differences into account. In densely populated areas with high production and consumption rates and low environmental protection standards, soil accumulation of cadmium is still likely.

b) The cadmium flow to landfills must have been small (~ 2 kt/yr). The reasoning is as follows: Since the input into the anthroposphere (exploitation) has not changed much, and the outputs by off gas and waste water have decreased by 80 %, the annual increase of the anthropogenic stock amounts roughly to 16 kt/yr if landfilling of cadmium containing wastes is assumed to be minimum (2kt/yr). Within 23 years and a linear increase of the anthropogenic stock from 6 to 162 kt/yr, the stock will increase to 230 kt/yr only. Assuming an exponential increase, the stock increases to 280 kt/yr. Thus, the anthropogenic stock can only increase to 500 kt if the net input into the anthroposphere was close to 16 tons for most of the time between 1980 and 2003. It can be hypothesized that in the beginning of the eighties, there was a transition in the use of cadmium from products such as plastic materials (as additives) that were incinerated and discarded to products such as accumulators that are recycled and thus stay in the anthroposphere.

Note: If 20 kt of cadmium are land-filled per year, it is nearly impossible that 300 additional kilotons of cadmium are accumulated in the anthroposphere: depending on the assumed figure for exploitation, the anthropogenic stock will decrease by 1.8 to 3.8 kt/yr. Thus, it must be assumed that in the past, the amount of cadmium leaving the anthroposphere has been comparatively small (a few kt/yr). In the far future, this amount may increase due to the end of the life time of long living cadmium products, shifting the main cadmium burden to landfills.

c) Suitable measures are: separate collection of batteries and recycling of cadmium, or collection and incineration together with MSW with recycling of cadmium removed by air pollution control and contained in filter residues (see Fig. 3.49). For both scenarios, and due to the atmophilic properties of cadmium, it is important that emissions to air are strictly controlled. Note that in the near future, NiCd batteries are likely to be superseded by more efficient and powerful nickel metal hydride and lithium ion cells. Thus, overall consumption of cadmium is likely to decrease considerably.

Solution 1.8: the figures given below are exemplary values for European urban areas; numbers can vary widely according to life style, economic conditions, household size, age group etc.

waste	waste category	mass flow [kg/c.yr] (as received)
food waste	MSW	90
paper	MSW	75
metals	MSW	12
wood	MSW	6
Glass	s.c. glass ¹	24
Newsprint	s.c. paper ¹	70
used car	end of life vehicle ELV	20
demolition waste ²	construction waste	1000
...		
...		

¹ s.c. separately collected

² total amount over lifetime divided by lifetime in years

- **Solution 1.9:** (no solution given) Discuss and evaluate your conclusion with the conclusion of someone else.

- Solution 2.1:** cf. Figure 2. Error 1: the system boundary is given as a box, like a process. Error 2: $\Sigma \text{ import} = \Sigma \text{ export}$ contradicts a total stock change rate of -200 units. Error 3: unit for flows is given but designated as fluxes. Error 4: the stocks are given in kt, while flows are given in t/yr. Flows (fluxes) and stocks should be given in corresponding units. Error 5: flow 4 is split up into two flows. This requires either another process (separation process) or assigning a clear process of origin to flows 5 and 8. Error 6: flow 12 gets “lost” in the system. A process of destination has to be specified. Error 7: flow 2 is not concerned by the system and thus must not be part of the analysis. Error 8: no flow rate is given for flow 6. Error 9: stock change rate of process 4 is wrong.

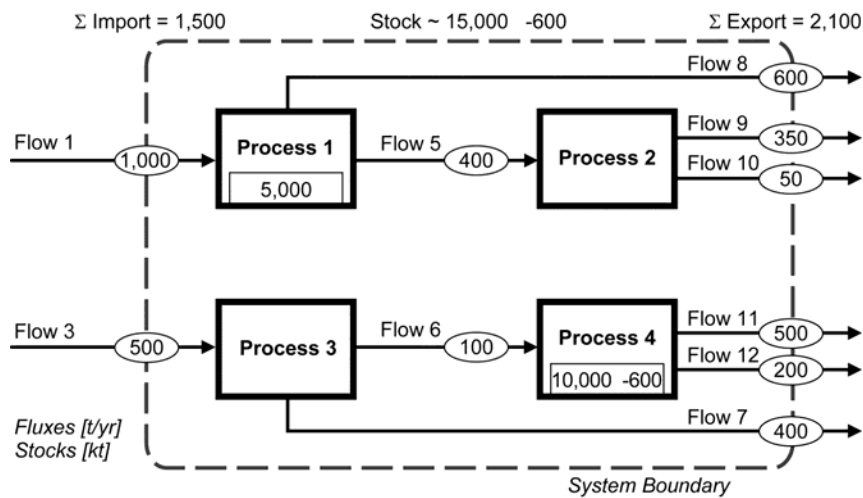

Figure 2 Corrected version of the flowchart shown in figure 2.14.

- **Solution 2.2:** cf. Table 2

Table 2 Selected units for flows, fluxes, and stocks

flow	flux	stock
t/yr	$\text{L}/(\text{m}^2 \cdot \text{s})$	mg/c
kg/h	kg/(c·yr)	Tg
L/d	$\mu\text{g}/(\text{m}^2 \cdot \text{yr})$	kg/m^3

m/s is the unit for velocity

- **Solution 2.3 a:** cf. Table 3

Table 3 Assessment of daily water consumption

process	specific consumption per capita	cycle	daily consumption L/(c·d)	share %
toilet flush	5-10 L/flush	6-10 times/d	30-100 (50)	37
shower	20-30 L/shower	once/d	20-30 (25)	18
bath tub	80-100 L/tub	once/2 weeks	6-7	4.7
body care	10 L/d		10	7.3
cooking	1 L/d		1	0.73
washing of dishes	10 L/d		10	7.3
room cleaning	5-10 L/cycle	once a week	1.5	1.1
laundry	100-250/cycle	once a week	15-35 (25)	18
drinking	2-3 L/d		2-3	1.8
car wash	50 L/cycle	4 times per year	0.5	0.37
(garden watering)	20-200 L/d	10-100 d/yr	0.5-55 (5)	3.7
total			97-253 (137)	100

- **Solution 2.4:** a) cf. Figure 3

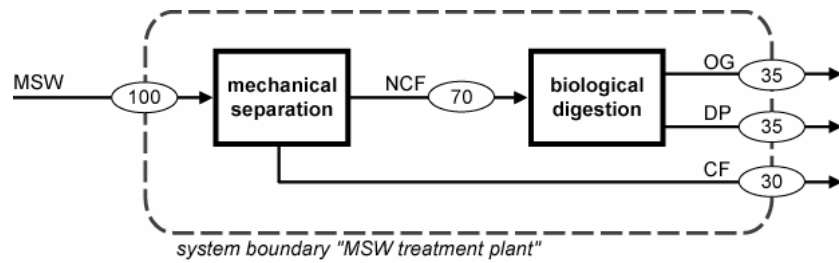

Figure 3 Flow chart of a MSW treatment plant. MSW ... municipal solid waste; NCF ... non-combustible fraction; CF ... combustible fraction; DP ... digestion product; OG ... off-gas

b)

$$TC_{CF} = 0.2, \quad [(1.0 \times 30) / (1.5 \times 100)]$$

$$TC_{OG} = 0.0012, \quad [(0.005 \times 35) / (1.5 \times 100)]$$

$$TC_{DP} = 0.79 \quad [(3.4 \times 35) / (1.5 \times 100)]$$

- **Solution 2.5:** cf. Table 4

Table 4 Assignment of substances to ranges of concentrations in the earth crust

average concentration in the earth crust	Substances
>10 %	O, Si
10-1 %	Na, Ca, Mg, Al, K, Fe
1-0.1 %	H, Ti, Mn
1,000-100 ppm	C, Cl, Rb,
100-10 ppm	Cr, Cu, Pb, Se, V, Zn
10-1 ppm	As, Tl
1,000-100 ppb	Cd, Sb
100-10 ppb	Hg, Ag,
10-1 ppb	Au

- **Solution 2.6:** cf. Table 5

Table 5 Assignment of goods to activities

activity	good and/or process
to nourish	chicken farm, fertilizer, gasoline
to clean	gasoline, sal ammoniac, vacuum cleaner, electrostatic precipitator, paper
to reside and work	gasoline, brick, fuel oil, shovel excavator, truck, cement factory, jeans
to transport and communicate	gasoline, truck, mobile phone, paper, cement factory

- **Solution 2.7:** the process “lithosphere” is a storage process with a negative rate of change (depletion); “extraction & production” denotes a transformation process of materials without a significant stock; “delivery & shipment” stands for the transportation of products (which are not chemically changed); “consumption & use” is a combination of transformation and storage of materials; same is true for “landfill”.

- **Solution 2.8:** anthropogenic: crop production, compost production, zoo, agriculture, forest management; geogenic: agricultural soil, planetary boundary layer, atmosphere, pedosphere, volcano, and river.

- **Solution 2.9:** determination of the ratio of concentrations [mg/kg] in sewage sludge and earth crust yields relevant substances (marked in bold, Table 6).

Table 6 Ratio of substance concentrations in sewage sludge and in the earth crust

	N	Cl	F	S	PCB	Cd	Hg	As	Co
sewage sludge	28,000	360	100	14,000	0.2	2	3	20	15
earth crust	20	130	625	260	0.05*	0.1	0.02	3.4	19
ratio	1,400	3	0.2	54	4	20	150	6	1
	Ni	Sb	Pb	Cr	Cu	Mn	V	Sn	Zn
sewage sludge	800	10	150	100	300	500	30	30	1,500
earth crust	45	0.2	15	88	35	800	109	2.5	70
ratio	18	50	10	1	9	1	0.3	12	21

* agricultural soil

Data for mean concentrations in the earth crust are tabulated in many reference works, e.g.ⁱ. If available more specific regional data should be applied. (What is the most abundant type of minerals in the region: carbonates, granite, basalt, etc.). Also mean geogenic concentrations in soil can be used as references.

For some substances the species might be relevant, e.g., for chromium (Cr^{III} is less toxic than Cr^{VI}).

Other substances to consider in the study may be found in Air and Soil Protection Acts as well as landfill directives.

ⁱ Kesler, S. E., *Mineral Resources, Economics and the Environment*, MacMillan College Publishing, New York, 1994.

ⁱⁱ Krauskopf, K. B., *Introduction to Geochemistry*, 2nd ed., McGraw-Hill, New York, 1979.

- **Solution 2.10:** a temporal system boundary of one to a few days will be too short in order to determine a reliable average. One year would be a reasonable time span although certain long-living goods such as furniture or a car may not be counted adequately. This can be solved by estimating the stock and considering aliquot fractions, e.g.: the usage of the car is 10 years and mass is 1.5 tons. Then the annual contribution of the car is 0.15 tons. The spatial system boundary can also be determined differently. The place (house, apartment, condominium) where you are living may serve as a system. In this case materials consumed outside your place will not be considered (materials for traveling, working, and so on). You may extend the system boundary and include also the production and service sector. This yields a much more complex system and will result in a significantly higher materials turnover. Such considerations may cause a new (and more exact) definition of the problem.

- **Solution 2.11:** a) cf. Figure 4

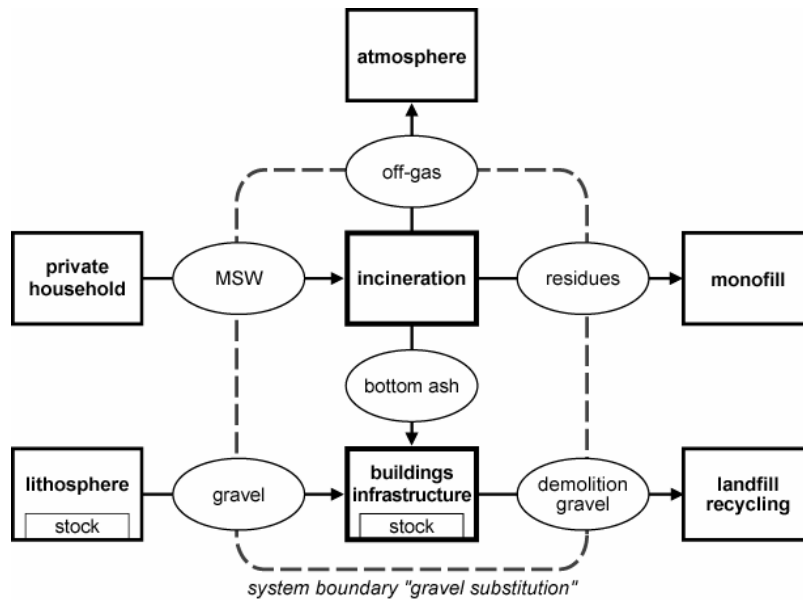

Figure 4 Appropriate flow chart to determine the contribution of bottom ash from MSW incineration to the substitution of gravel.

b) data required: MSW generation: 300 – 700 kg/(c·yr); generation of bottom ash: 200-350 kg/t MSW; mass reduction by mechanical separation of unwanted materials: 10 % (assumption); consumption of primary gravel: 4.6 t/(c·yr)ⁱⁱⁱ.

resource conservation: 350 kg of MSW yield $350 \times 0.3 \times 0.9 = 95$ kg of bottom ash for, e.g., road construction. Hence, ca. 2 % of primary gravel can be substituted. It can be concluded that this practice will not solve shortage problems in gravel supply. Note that the chemical composition of bottom ash differs considerably from that of gravel (cf. Problem 2.12).

ⁱⁱⁱ Baccini, P. and Bader, H.-P., *Regionaler Stoffhaushalt*, Spektrum Akademischer Verlag, Heidelberg, Germany, 1996.

- **Solution 2.12:** Table 7 shows that employment of bottom ash in construction would significantly change the flows and, in the long run, stocks of hazardous substances (C_{org} , Cu, Zn, Pb, and Cd) in the infrastructure. This could be prevented by treatment of the bottom ash (decontamination process) or by a change in MSW composition.

Table 7 Ratio (R) of substance concentrations in MSW incineration bottom ash (BA) and in gravel (G).

	Si	Al	Fe	Mg	Ca	K	C_{org}	Cu	Zn	Pb	Cd	Hg
	%	%	%	%	%	%	%	g/kg	g/kg	g/kg	mg/kg	mg/kg
BA	20	4	3	1	10	1	2	2	10	6	10	0.5
G	20	4	2	0.16	20	0.17	<< 0.1	0.01	0.06	0.015	0.3	0.05
R	1	1	1	6	0.5	6	>>20	200	170	400	33	10

- Solution 2.13:** average lifetime assumed to be 75 yrs; MSW generation = 350 kg/(c·yr); construction and demolition waste: few data is available, estimates are >500 kg/(c·yr), increasing tendency; sewage sludge: 60 kg/(c·yr), water content = 66 %; end-of-life vehicles: 70 kg/(c·yr); hazardous wastes: 80 kg/(c·yr); industrial wastes: few data is available, estimates are >500 kg/(c·yr). All together at present waste generation is >1,500 kg/(c·yr) or >110 t per average lifetime (result a), corresponding e.g. to the mass of more than 80 passenger cars. The volume is approximately 100 – 200 m³, a cube having edges of ca. 5 m. For a person 25 years old, linear growth (+20 kg/(c·yr)) yields 130 t/(c·75yr), and exponential growth 160 t/(c·75yr); cf. Figure 5.

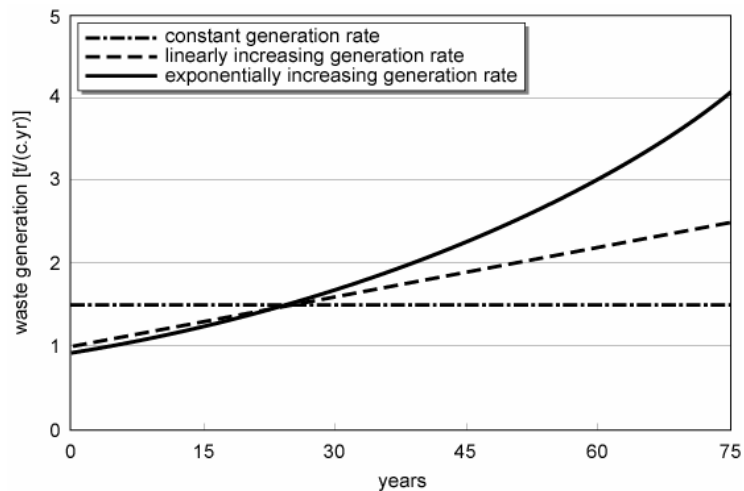

Figure 5 Assessment of the total waste generation across the life time of a 25 years old person, today's waste generation is ca. 1.5 t/(c·yr).

- **Solution 2.14:** all figures are related to 1 hectare [ha] = 10,000 m². The top 30 cm of soil are turned over by ploughing (plough layer); → the “dilution volume” for sewage sludge is 3,000 m³; density of soil is 1.5 t/m³; → “dilution mass” is 4,500 t; → 1 ha of agricultural soil (top layer) contains 135 kg Zn; → max. flux of Zn via sewage sludge to agricultural soil = 135 kg·0.05/100 yrs = 0.068 kg/(ha·yr); Zn in sewage sludge = 1,500 mg/kg; → 45 kg/(ha·yr) of sewage sludge can be applied; average specific sewage sludge generation is ca. 25 kg/(c·yr) dry matter (cf. solution to problem 2.13) ; → 0.53 ha/c of agricultural soil are required; agricultural soil in the European Union is 0.4 ha/c.

- **Solution 2.15:** the system exports all kinds of wastes, → all material flows due to waste treatment and storage are excluded; concentrates, semi-products, and final products are imported, → the “rucksack” of these material flows is not considered; recycling of materials occurs outside, too, → associated material flows are not part of the system. Altogether, the proposed system excludes many material flows and stocks such as emissions, waste flows, and final deposition of wastes.

- **Solution 2.16:** See for instance:

<http://www.shell.com/> (e.g. “Meeting the energy challenge – The Shell report 2002”)

<http://www.basf.de/en/corporate/sustainability/ub02/> (e.g. page 30 ff. “Environment, Health and Safety Report 2002”)

• **Solution 3.1:** a) The large particles deposited in the vicinities of roads comprise about 25 % of the lead deposited in the region (cf. input of 0.44 t/yr into the process “urban area”). A major fraction of lead is emitted in small particles; they have a residence time in the air of several days and are distributed over wide areas. Thus, a regional ban on leaded gasoline will reduce mainly the deposition of large particles. Imports and exports of small particles will be affected only marginally. Hence, the regional atmospheric deposition will be reduced by about 25 % only. In order to significantly decrease the deposition of lead in the investigated region, it is necessary to take national or even international measures. Only a ban in several countries covering a large area allows a significant reduction by one order of magnitude. Note that the lead input into the soil by sewage sludge will decrease too because of the reduced lead input into the sewer. Still, agricultural soils will receive an amount of lead that is much larger than the output. b) Lead input into the soil by sewage sludge is as important as atmospheric deposition. If sludge is land filled or incinerated, the load of lead to the soil will be reduced by 54%. Note that this reduction is not enough to prevent accumulation in the soil: assuming constant soil leaching rate of f lead, the input by atmospheric deposition is still larger than the output. But the time span will be extended until lead standards for soil are reached and surpassed. If sludge is land filled, the stock in landfills will not be changed much; the disposal of car shredder residues results in a mass flow that is two orders of magnitude larger than lead in sewage sludge. c) At present, MSW is treated outside the region. If MSW of neighboring regions is used within the region as a fuel for an incinerator equipped with sophisticated air pollution control devices, the lead emissions to air are of no concern: The efficiency of 99.99 % means that at most 0.01 % of lead in MSW is emitted into the atmosphere. In practice, the emission will be even smaller, because the transfer coefficient for lead from MSW to untreated off gas is < 1.0 (~ 0.4). 0.01 % of 56 t/yr (280,000 persons) yields a lead flow to the atmosphere and soil of 0.0056 t/yr; this is less than 1 % of the atmospheric deposition flow. Disposing of bottom ash and filter residues in the regional landfill will double the accumulation of lead thus improving the potential for future reuse of the landfill as a source for heavy metals.

- **Solution 3.2:** a) and b) cf. Figure 6

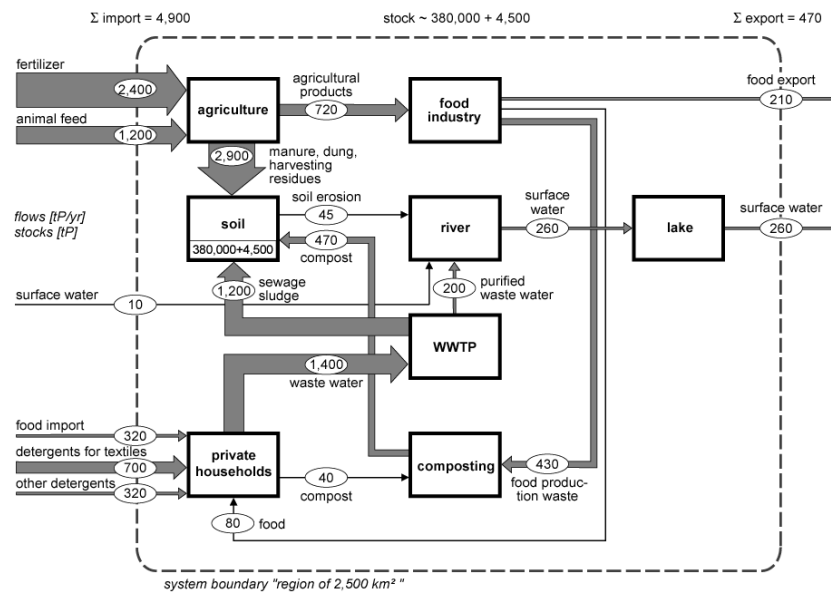

Figure 6 Stocks and flows of P in a region of 2,500 km² and 1 Mio. inhabitants. For easier visualization, all numbers are rounded to two digits, thus inputs and outputs of certain processes (private households) may appear to be not in balance.

The annual input of P to soil is 4,500 t/yr; doubling time of P concentrations in soil is about 85 yrs.

c) Without a ban of P in laundry detergents, the concentration of P in the lake is: $259/2,800 = 0.09 \text{ t}/(10^6 \text{ m}^3) = 0.09 \text{ mg/L}$. Phasing out P in laundry detergents reduces the P-flow from households to WWTP to 660 t/yr. Thus, purified wastewater has a P-load of $660 \cdot 0.15 = 99 \text{ t/yr}$. P-flow into the lake is $45 + 10 + 99 = 154 \text{ t/yr}$, resulting in a P-concentration of $0.09 \cdot 154/259 = 0.05 \text{ mg/L}$. The measure is not sufficient to prevent eutrophication.

d) Ban of P in all detergents. Reduce P-load to soil and thus reduce erosion of P. Take agricultural measures to prevent erosion. Increase the TC of P into sewage sludge by improving P elimination.

- **Solution 3.3:** a) The large stock in the soil and the constant erosion of soil means that there will be no significant reduction effect until the stock decreases. Hence, if the reduction of fertilizer reduces the P input into the soil below the P output, an effect will be observed in several years to decades only. If P input still exceeds output, no effect will be seen. b) Due to high costs, implementation will take ~ 5 to 10 years. The effect will be quite small: About 8 % (direct discharge: 6 %, and base flow: 2 %) of P will be collected (cf. Table 3.13), and about half of these 8 % will be retained by waste water treatment. Thus, the reduction will be only 4 % of total input. c) A reduction of about 10 % can be achieved in a period of two to five years at smaller costs than in b). d) A ban of direct discharges will have severe consequences for the agricultural sector. From a technological point of view, implementation could be fast (one to two years), but from an economic and social acceptance point of view, the reaction time will be much longer: probably five to ten years for affluent societies, and 10 to 20 years for economies in the lower Danube basin. e) A ban on (or a voluntary replacement of) P-containing detergents can be implemented fairly (~ one year) quickly since alternative products are available at about the same costs. It can reduce the total input to the river Danube by about 7 %. f) A general conclusion is that one measure alone cannot decrease much the input of P into the river Danube. It takes a whole array of decisions to successfully protect the river system from anthropogenic activities.

- **Solution 3.4:** the input of substances As, Se, Hg, S, Cl, and N in fuel is higher for the power plant than for the incinerator. Modern incinerators obey the most stringent emission limits of, e.g., EU legislation. With respect to air pollution control this means that power plants should have the same or even lower transfer coefficients into the off-gas than MSW incinerators. Considering the-state-of-the-art in flue-gas cleaning of MSW incinerators it can be concluded that the power plant requires very efficient collection of particulates ($<10 \text{ mg/Nm}^3$, N stands for standard temperature and pressure STP), removal of sulphur (e.g., absorption of SO_2 in a wet scrubber), reduction of NO_x and perhaps removal of HCl (dry or wet).

Table 8 Comparison of the through-put of a coal-fired power plant and of a MSW incinerator.

	coal	MSW	coal	MSW	coal/MSW
	mg/kg	mg/kg	kg/h	kg/h	-
As	12	10	3.6	0.3	12
Pb	6	500	1.8	15	0.12
Cd	0.1	10	0.03	0.3	0.1
Cu	13	1,000	3.9	30	0.13
Se	0.9	1	0.27	0.03	9
Zn	27	1,200	8.1	36	0.23
Hg	0.3	1	0.09	0.03	3
S	6,500	3,000	2,000	90	22
Cl	1,000	7,000	300	210	1.4
N	12,000	5,000	3,600	150	24

- **Solution 3.5:**

If plants are produced by hydro cultures assuming no losses of nutrients, and animals are fed by such plants without the use of soils, the following nutrient flows result:

Phosphorous flow in [kg per capita and year] (phh: private household; p&d: processing and distribution)

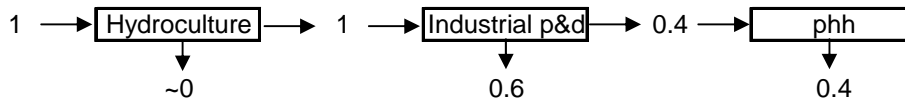

The need for P in agriculture can be reduced by 80 %, while the input into private households remains the same. There will be no accumulation of P in soils anymore.

Nitrogen flow in [kg per capita and year]

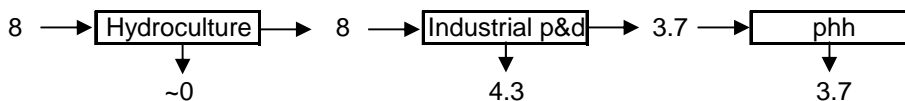

The need for N in agriculture can be reduced by 56 %, while the input into private households remains the same.

The losses of nutrients from agriculture to the environment (water, soil, and air (N)) are highly reduced. Wastes from industry and household are becoming relatively more important sources of nutrients; if recycled, they can supply a large portion of the demand. In the following table, it is assumed that all nutrient wastes can be recycled.

Fractions [%] of demand that can be supplied by wastes from	Private households	Industrial p&d	Phh and industrial p&d
P agriculture	8	12	20
P hydro culture	40	60	100
N agriculture	20	24	44
N hydro culture	46	54	100

• **Solution 3.6:**

(Please note Errata for Table 3.30 in problem 3.6: Zn content of „Zn scrap“ should read 8% and not 11%.)

a) cf. Figure 7

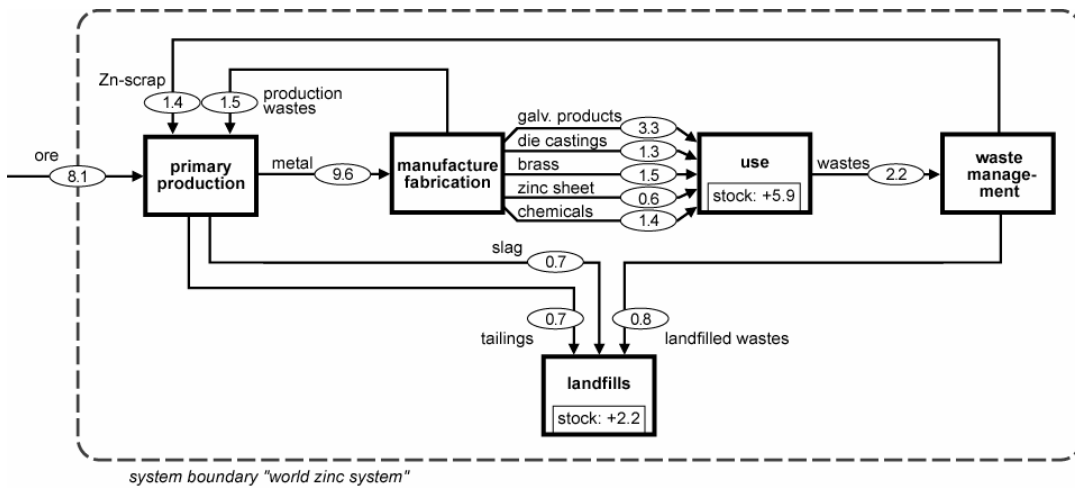

Figure 7 Flowchart of the system: rough zinc balance for the world

b) cf. Figure 8

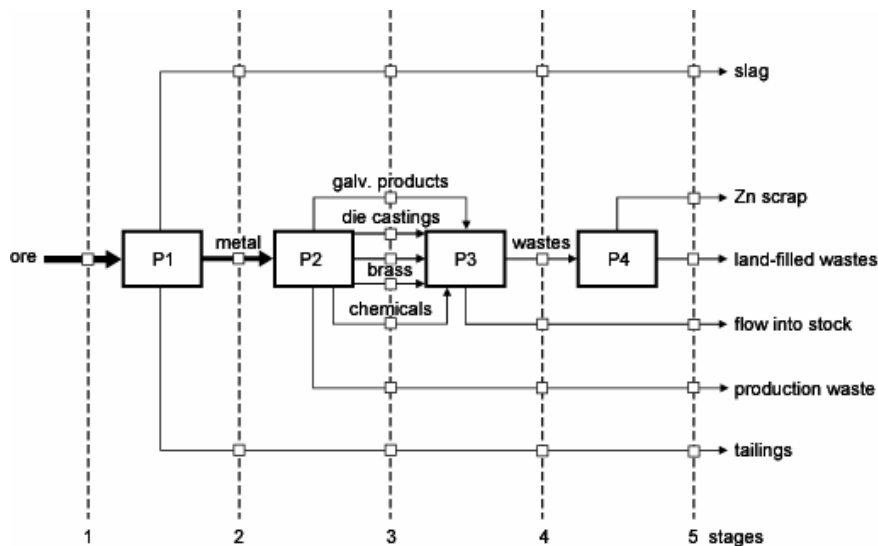

Figure 8 Assignment of material flows to stages.

c) Exemplary calculation of stage 4 (Table 9)

The material flows to consider in stage 4 are (cf. Figure 8): slag, wastes, flow into stock, production waste, and tailings.

$$\sum \dot{X}_i = 0.7 + 2.2 + 5.9 + 1.5 + 0.7 = 11 \text{ Mio. t/yr}$$

$$\tilde{m}_i = \frac{\dot{m}_i}{\sum \dot{X}_i}$$

$$H = -\sum \tilde{m}_i \cdot c_i \cdot \text{ld}(c_i)$$

Table 9 Calculation of statistical entropy H for stage 4.

goods of stage 4	\dot{m}_i	\tilde{m}_i	c_i	$\tilde{m}_i \cdot c_i$	$\text{ld}(c_i)$	$\tilde{m}_i \cdot c_i \cdot \text{ld}(c_i)$
	Mio. t/yr	kg/kg Zn	kg Zn/kg	-	-	-
slag	14	1.3	0.05	0.063	-4.3	-0.28
wastes	810	74	0.0027	0.2	-8.5	-1.7
flow into stock	2,200	200	0.0027	0.54	-8.5	-4.6
production waste	3	0.3	0.5	0.14	-1	-0.14
tailings	230	21	0.003	0.063	-8.4	-0.53
Σ						-7.2

$$H_4 = 7.2$$

$$H_{\max} = \text{ld}(1/c_{EC})$$

$$c_{EC} = 0.00007 \text{ kg Zn/kg earth crust}$$

$$H_{\max} = 13.8$$

$$\text{RSE}_4 = H_4/H_{\max} = 0.52$$

Results for other stages: $\text{RSE}_1 = 0.31$, $\text{RSE}_2 = 0.06$, $\text{RSE}_3 = 0.28$, $\text{RSE}_5 = 0.49$

Figure 9 illustrates that the system shows an increasing entropy trend. This means that less zinc is available at the end of the life cycle and more zinc is “lost”.

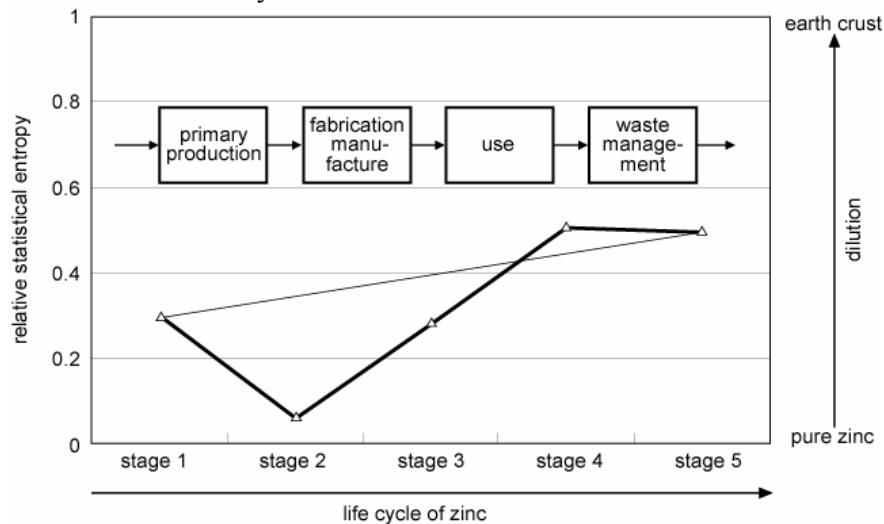

Figure 9 Entropy trend across the life cycle of zinc.

d) Loss to the environment is assumed to 15 % of used zinc ($8.1 \cdot 0.15 = 1.22$ Mio. t/yr). This changes the RSE of stages 4 and 5. Zn flow into stock is $5.9 - 1.2 = 4.7$ Mio. t/yr; total flow into stock is $4.7/0.0027 = 1,740$ Mio. t/yr. Loss is evenly dispersed in soil, i.e., concentration of average earth crust can be taken (0.00007 kg Zn/kg), total mass of loss is $1.22/0.00007 = 17,428$ Mio. t/yr (Table 10).

Table 10 Calculation of statistical entropy H for stage 4' (including dissipation).

goods of stage 4'	\dot{m}_i	\tilde{m}_i	c_i	$\tilde{m}_i \cdot c_i$	$\text{ld}(c_i)$	$\tilde{m}_i \cdot c_i \cdot \text{ld}(c_i)$
	Mio. t/yr	kg/kg Zn	kg Zn/kg	-	-	-
slag	14	1.3	0.05	0.063	-4.32	-0.28
wastes	810	73.6	0.0027	0.2	-8.53	-1.7
flow into stock	1,740	158	0.0027	0.43	-8.53	-3.64
dissipative loss	17,428	1,584	0.00007	0.11	-13.8	-1.53
production waste	3	0.3	0.5	0.14	-1	-0.14
tailings	230	20.9	0.003	0.063	-8.38	-0.53
Σ						-7.81

$$H_{4'} = 7.8$$

$$RSE_{4'} = 0.57; RSE_{5'} = 0.53$$

Figure 10 shows that dissipation of zinc may significantly influence the entropy trend of the system.

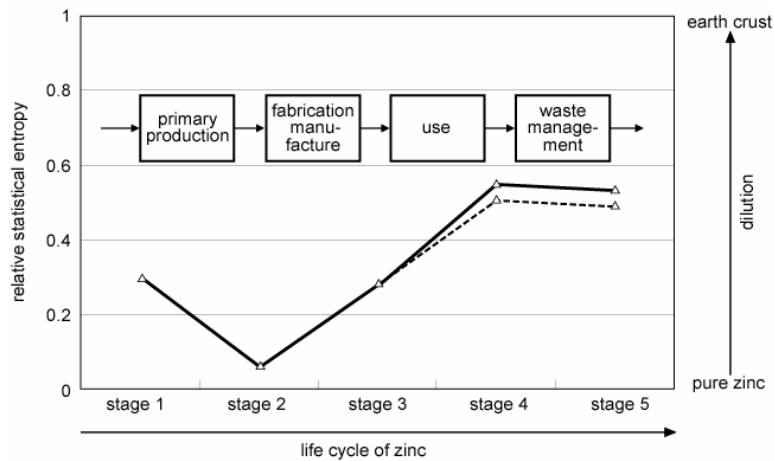

Figure 10 Entropy trend across the life cycle of zinc including the assumption that 15 % of the consumed/used zinc are dissipated.

- **Solution 3.7:** a) stock in building construction: $180 + 100 \cdot 4 = 580$ t/c; stock in underground construction: $160 + 100 \cdot 2 = 360$ t/c; stock in geogenic gravel reservoir: $1000 - 8 \cdot 100 + 0.01 \cdot 100 = 201$ t/c.
b) At present 100 % recycling (not realistic) could substitute 33 % of primary resources (9 t/(c·yr)). If construction is in steady-state (input = output) then recycled material could substitute up to 80 %.
c) The landfills represent the fourth stock: >300 t/c after 100 yrs. The composition of demolition debris is different from geogenic gravel and sand. Some fractions (concrete, bricks, stones) have comparable quality when carefully separated and collected from the deconstruction site. Mixed construction wastes require pretreatment (sorting, separation of contaminants). A fraction of 10-30 % cannot be recycled and has to be incinerated and finally land filled.

Solution 3.8:

Table 3.29 shows, that (short living) packaging plastics contain comparatively low concentrations of heavy metals, while plastics with long residence times are stabilized to resist degradation by light, temperature, micro-organisms and chemicals and thus include large amounts of additives and heavy metals. The flow of heavy metals in non-packaging plastic material is large: 250 t/yr of Ba/Cd stabilizers and 1600 t/yr of Pb stabilizers. Hence, the treatment and utilization of packing and non-packing wastes requires specific and separate measures: thermal processes treating non-packaging plastic wastes must be able to cope with large amounts of heavy metals. Since some of the metals are atmophilic (Cd), advanced air pollution technology is needed to remove these metals that are concentrated on small particles in the off gas. Simple cyclones, scrubbers or other dust filters are well suited to remove large particles. To remove atmophilic heavy metals, high efficiency bag house filters, electrostatic precipitators, ventury scrubbers with very large pressure drops and similar devices or combinations are required. Because of formation of chlorinated dioxins due to chlorine containing plastics (PVC), dioxin removal is required additionally. In the following table, advantages and disadvantages of blast furnaces and MSW incinerators are discussed.

Criteria	Blast furnace	MSW incinerator	Advantage for
Environmental loadings	Higher emissions to air and soil due to less controlled total off gas volume and due to less stringent air pollution control regulation. No heavy metal flows to land fills.	Lower emissions due to complete control over volumetric off gas flow and due to very high air pollution standards and highly developed air pollution control technology for dust, Hg, Dioxins, NO _x , SO ₂ , and HCL. Metal flows to landfill.	Air: MSW incinerator Soil: MSW if solid residues are pretreated before land filling.
Resources	Heavy metals are either incorporated in filter residue or in steel. Filter residue can be recycled for metal recovery. Heavy metals in steel can decrease steel quality and are entering the steel recycling cycle.	Heavy metals are either incorporated in filter residue or in bottom ash. Filter residue can be recycled for metal recovery. Heavy metals in bottom ash prevent the use of ash as construction material and require pre-treatment before land filling.	More or less equal: Steel contamination versus ash contamination.
Final sinks	Most materials are kept in useful cycles, some in contaminated (steel) cycles. No material is directed to appropriate final sinks.	If not recycled, bottom ash and filter ash can be immobilized and are well suited for disposal in appropriate final sinks.	Ultimately, MSW incineration directs more heavy metals to final sinks, "cleans" the anthroposphere.

Solution 3.9: the following system might be appropriate to determine the paper content in MSW (Figure 11). It is important to find out the actual domestic paper consumption [t/yr or kg/(c·yr)]. This figure might be different from total paper production due to import/export. The paper flow via MSW can be assessed as difference between domestic paper consumption and waste paper (domestic and export). To calculate the paper content in MSW [kg paper /t MSW] the generation rate of MSW [t/yr] has to be known.

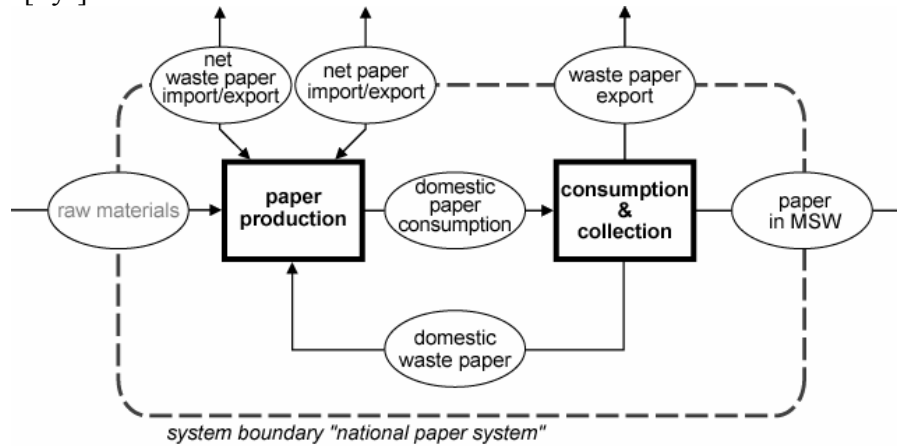

Figure 11 Possible system to determine the paper content in MSW.

- **Solution 3.10:** (the following tables and figures refer to Obernberger et al.). The partitioning of ashes is given in Table 3, e.g., bottom ash 87 %, boiler and cyclone fly ash 5 %, filter fly ash 6.5 %, and flue dust 0.5 %. Ash content of cereals is given in Figure 6: 5.3 % (d.b.). This gives the following ash flows (in kg per ton cereals combusted): bottom ash 43.8, boiler and cyclone fly ash 2.5, filter fly ash 2.8, and flue dust 0.25. Concentrations in ashes can be roughly taken from Figure 9 (in mg/kg d.b.): bottom ash 0.2, boiler and cyclone fly ash 1, and filter fly ash 8. Now the flows via ash fractions can be calculated (in mg/t cereals): bottom ash 8.8, boiler and cyclone fly ash 2.5, and filter fly ash 22, together ca. 33 mg/t. The resulting partitioning of Cd between the ash fractions corresponds well enough with the partitioning given in Figure 8. Considering all uncertainties Cd concentration of cereals can be assumed between 0.03-0.04 mg/kg.

- **Solution 3.11:** the largest flow of Cd is led into reactor-type landfills by direct landfilling. This is a reservoir that cannot be separated from the hydrosphere over longer periods (decades to centuries). Smaller amounts of Cd are directed towards combustion processes. High-standard combustion transfers most Cd (filter residue) into safe underground disposal facilities. A minor part (bottom ash) goes to monofills. Low-standard combustion directs a substantial amount of Cd into the atmosphere and is the only source of Cd pollution in this compartment. 3.5 t/yr of Cd are returned to the economy. (Note that this Cd is not recovered and used as a secondary resource but is contained in products like concrete, paper, chipboards, etc. Hence, it does not have a positive function in these products.) The only appropriate final sink for Cd are therefore underground disposal facilities; only 10 % of the Cd input into waste management is directed to these final sinks.

- **Solution 3.12:** 1. the product should not be a sink for pollutants. Some manufacturers prefer for image reasons that cement and concrete is not associated with waste disposal and heavy metals contamination. 2. Once becoming a constituent of concrete heavy metals are no longer available for recovery. 3. The long-term behavior of metals in products made of concrete is not fully known (application of the precautionary principle). 4. Thinking in “sustainability time spans” (centuries), multiple recycling loops may lead to accumulation of heavy metals in concrete.

- **Solution 3.13:** a) all flows are related to 1 ton of MSW. Copper in MSW is 1 kg. 0.9 kg is transferred into bottom ash. Ca. 0.54 kg of Cu is recovered; the recovery efficiency is 54 %.
- b) Figure 12 shows the flow chart of the system, the following table gives flow-rates and Cu concentrations of all required flows. The SCE values are calculated as shown in Chapter 2.5.1.8.

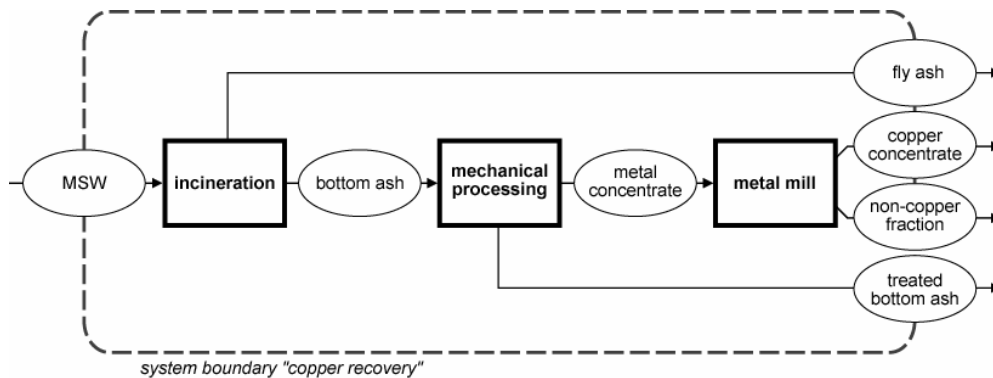

Figure 12 Flow chart for the process chain “incineration, mechanical processing, and metal mill”.

Table 11 Mass flows and copper concentrations for the system “copper recovery”

goods	flow-rates [kg/t MSW]	Cu conc. [kg Cu/kg]
MSW	1,000	0.001
fly ash	25	0.004
bottom ash	250	0.0036
metals concentrate	1.1	0.5
treated bottom ash	250	0.0014
copper concentrate	0.55	1
non-copper fraction	0.55	0

SCE after incineration: 19 %

SCE after mechanical processing: 53 %

SCE after metal mill: 59 %

- c) Additional information is needed to answer this question reliably. For example the mechanical approach has to be compared to other technologies (thermal and biochemical). Energy demand, costs and environmental impacts have to be observed. Other relevant metals have to be included into the decision making process. Seen solely from the point of view of copper this kind of recovery can be rated as quite efficient.

• **Solution 3.14:**

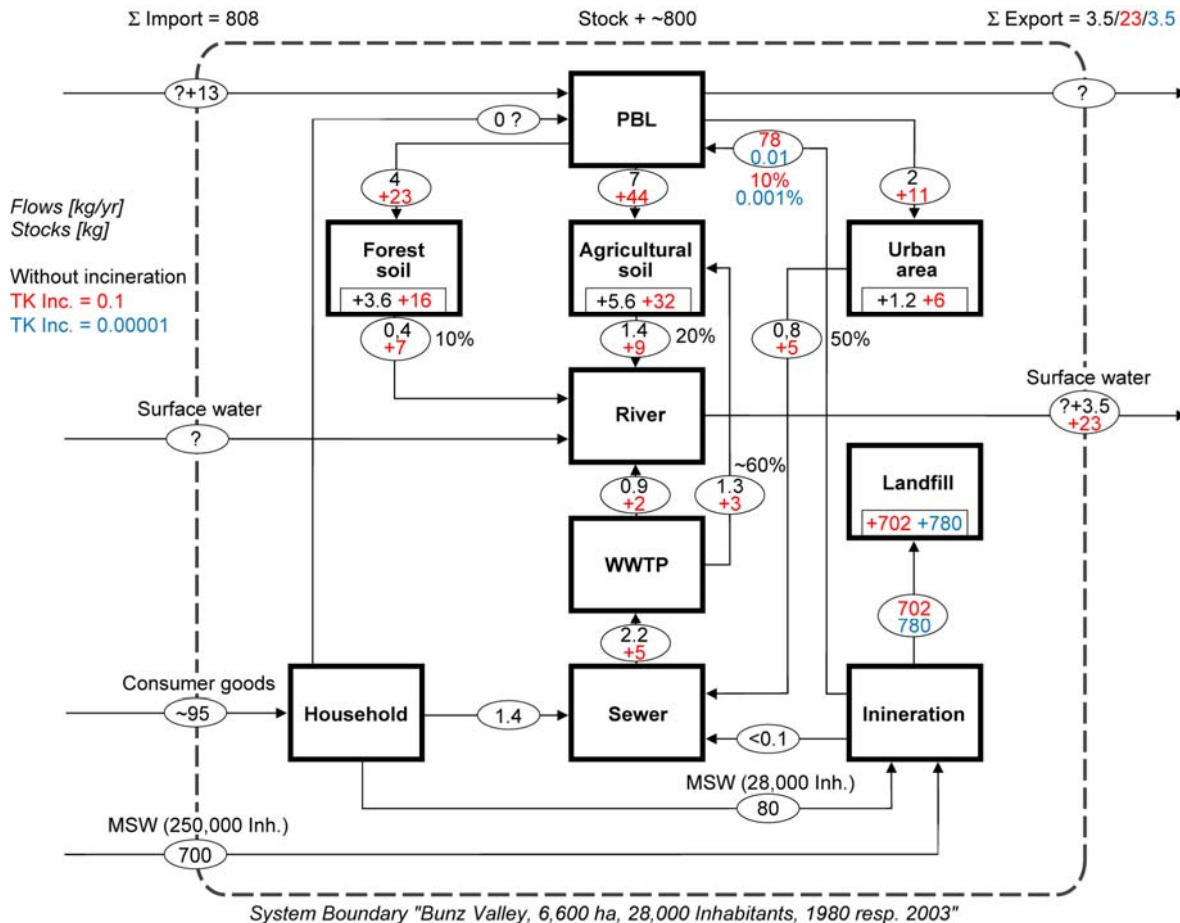

Cadmium flows and stocks in the Bunzvalley. Assumption: fraction of cadmium leached and eroded from soils to river is equal to lead. This supposition is a first approximation only, for a correct assessment, soil properties have to be taken into account.

a) Major flows with old technology (figures in red):

MSW, ash and filter residues to landfills, emissions to air and soil.

b) Major changes with new technology (figures in blue):

Very large reduction (- 99.98%) in air pollution thus only small flows to air and soil, small (+ 10%) increase in flow to landfill.

c) Old technology: severe soil pollution of cadmium; large stock of cadmium in landfills which represent a large reservoir for future use, but cadmium has to be confined for very long time periods; large river export may have an effect on downstream lakes if any.

New technology: no air pollution, insignificant flow to the atmosphere when compared to the "natural" flows without incineration. No accumulation in soil. More cadmium is land filled; if properly managed (separate storage of highly concentrated filter residue and of "diluted" bottom ash), it represents a potential future resource.